

# MA3B

## series

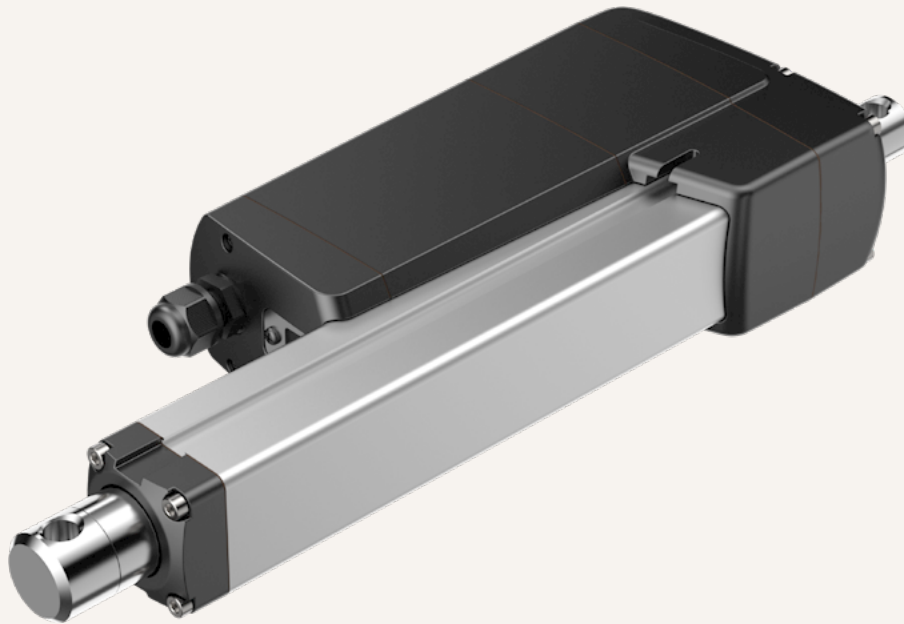

### Product Segments

- **Industrial Motion**

TiMOTION's MA3B series is a heavy-duty industrial actuator designed for reliable performance in harsh environments. Powered by a brushless DC (BLDC) motor, it ensures extended service life, superior efficiency, and reduced maintenance demands. Built to deliver high load capacity, the MA3B is ideal for applications requiring long-lasting durability, including material handling, construction, and outdoor power systems.

The MA3B comes equipped with a built-in driver board, eliminating the need for an external control box. It also incorporates the core type of an intelligent actuator. When paired with TiMOTION's PGMA software, it provides users with the flexibility to configure key parameters—including speed, stroke limits, soft-start, soft-stop, and more—ensuring optimal adaptability across a wide range of applications.

#### General Features

Max. load	10,000N (push/pull)
Max. speed at max. load	11.9mm/s
Max. speed at no load	35.8mm/s
Retracted length	≥ Stroke + 230mm
IP rating	IP69K
Stroke	30~800mm
Output signals	Hall sensor * 2 input to PCBA (No output)
Options	Max. life: up to 200,000 cycles (4,000N)
Voltage	12/24V DC
Operational temperature range	-40°C~+85°C
Operational temperature range at full performance	+5°C~+45°C

## Drawing

Standard Dimensions  
(mm)

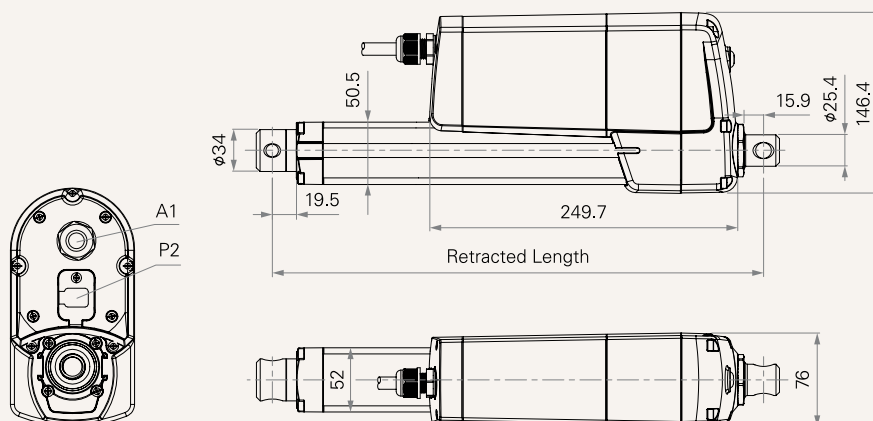

## Load and Speed

Spindle Type	CODE	Load (N)		Self Locking Force (N)	Duty Cycle	Typical Current (A)		Typical Speed (mm/s)	
		Push	Pull			No Load 24VDC	With Load 24VDC	No Load 24VDC	With Load 24VDC
<b>5729 Brushless DC Motor</b>					<b>4300rpm With Load</b>				
Ball screw	<b>B</b>	4000	4000	5200	25%	3.0	13.0	35.8	35.8
	<b>C</b>	7500	7500	9750	25%	3.0	12.8	17.9	17.9
	<b>D</b>	10000	10000	13000	25%	3.0	11.5	11.9	11.9

## Note

- 1 Please refer to the approved drawing for the final authentic value.
- 2 The current & speed in table are tested with 24V DC motor. With a 12V DC motor, the current is approximately 1.5 times the current measured in 24V DC; the speed is approximately three-fourths of the speed measured in 24V DC.
- 3 The current & speed in table are tested when the actuator is extending under push load.
- 4 The current & speed in table and diagram are tested with a stable power supply at rated voltage.
- 5 Without load, noise level  $\leq 78$ dB(A) (by TiMOTION test standard, ambient noise level  $\leq 36$ dB(A)).
- 6 Standard stroke: Min. 30mm, Max. please refer to below table.

CODE	Load (N)	Max Stroke (mm)
<b>B</b>	$\leq 5000$	800
<b>C, D</b>	$\leq 10000$	600

**Performance Data (24V DC Motor)**

4300RPM with Load

Speed vs. Load

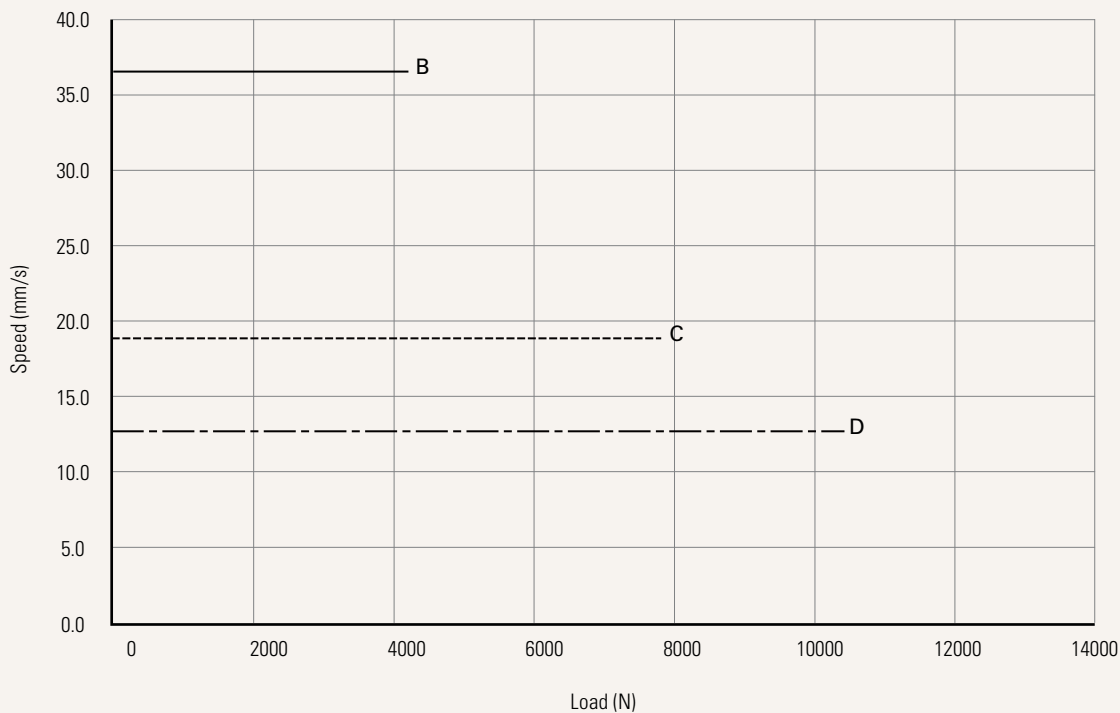

Current vs. Load

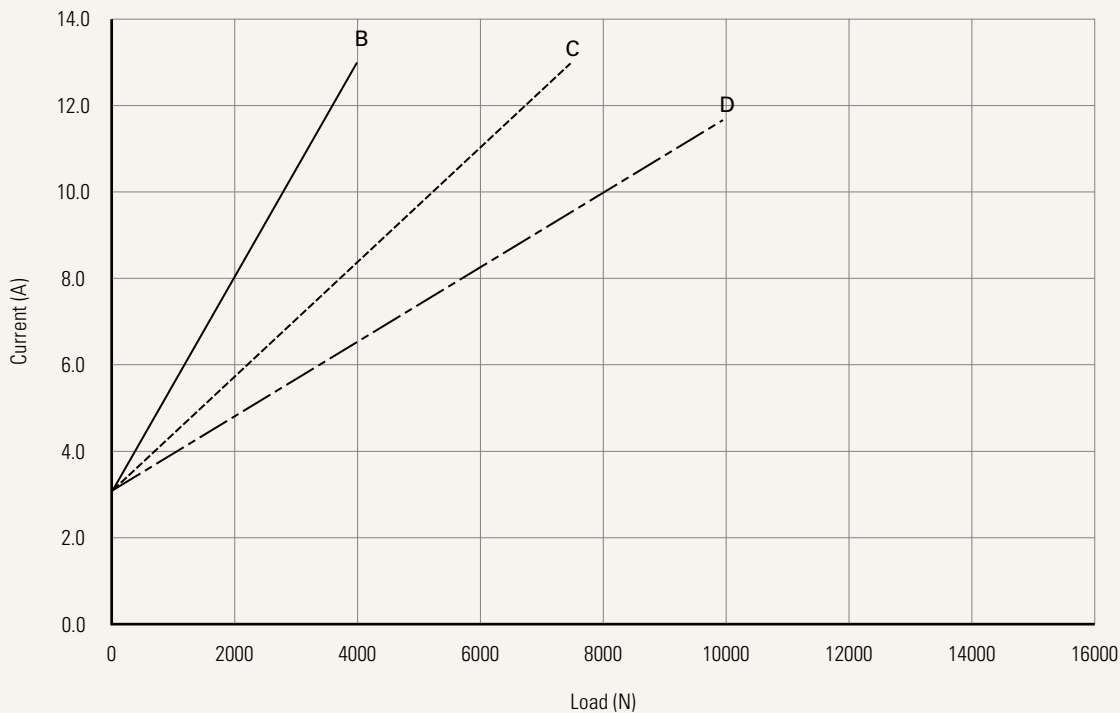

<b>Type</b>	C = BLDC driver + basic / core function		
<b>Voltage</b>	1 = 12V DC	2 = 24V DC	
<b>Load &amp; Speed</b>	<a href="#">See page 2</a>		
<b>Stroke (mm)</b>	<a href="#">See page 2</a>		
<b>Retracted Length (mm)</b>	<a href="#">See page 8</a>		
<b>Rear Attachment (mm)</b> <a href="#">See page 9</a>	1 = #45 Steel, slotless, hole 10.2 2 = #45 Steel, slotless, hole 12.8 3 = #45 Steel, U clevis, slot 8.2, depth 15.0, hole 10.2 4 = #45 Steel, U clevis, slot 8.2, depth 15.0, hole 12.8 5 = Stainless Steel, slotless, hole 10.2 6 = Stainless Steel, slotless, hole 12.8	7 = Stainless Steel, U clevis, slot 8.2, depth 15.0, hole 10.2 8 = Stainless Steel, U clevis, slot 8.2, depth 15.0, hole 12.8 9 = #45 Steel, slotless, hole 16.2	
<b>Front Attachment (mm)</b> <a href="#">See page 9-10</a>	1 = #45 Steel, slotless, hole 10.2 2 = #45 Steel, slotless, hole 12.8 3 = #45 Steel, U clevis, slot 8.2, depth 15.0, hole 10.2 4 = #45 Steel, U clevis, slot 8.2, depth 15.0, hole 12.8 5 = Stainless Steel, slotless, hole 10.2 6 = Stainless Steel, slotless, hole 12.8	7 = Stainless Steel, U clevis, slot 8.2, depth 15.0, hole 10.2 8 = Stainless Steel, U clevis, slot 8.2, depth 15.0, hole 12.8 9 = #45 Steel, slotless, hole 16.2 K = Rod end bearing, hole 12.8	
<b>Direction of Rear Attachment (Counterclockwise)</b>	1 = 0°	2 = 45°	3 = 90°      4 = 135°
<b>Function of Limit Switches</b>	7 = Sending hall signals at EOS to control board		
<b>External Signal of Actuator</b>	0 = Without 1 = Reed switch * 1, tinned leads (NC, signal to customer control system) 2 = Reed switch * 2, tinned leads (NC, signal to customer control system) 3 = Reed switch * 1, tinned leads (NO, signal to customer control system) 4 = Reed switch * 2, tinned leads (NO, signal to customer control system) B = Reed switch * 1, Molex 6p C = Reed switch * 2, Molex 6p		
<b>Output Signal</b>	T = Hall sensor * 2 input to PCBA (No output)		
<b>IP Rating</b>	1 = Without 6 = IP66M	7 = IP67 8 = IP68	9 = IP69K



<b>Cable Exit</b>	T = Direct cable out, 1+1 type: Military connector (A1) + Molex 6P connector (P2)	
<b>A1 / P1 Connector (mm)</b>	01 = Tinned leads, unsheathed wire 50, stripped wire 10 <a href="#">See page 10</a>	
<b>A1 / P1 Cable Length (mm)</b>	XXXX = Input 4 digital number directly, range 0-5000, multiples of 100 (e.g. 500, enter 0500)	
<b>P2 Connector</b>	0P = Rubber seal plug	
<b>P2 Cable Length (mm)</b>	0000 = Without	
<b>P3 Connector</b>	00 = Without	
<b>P3 Cable Length (mm)</b>	0000 = Without	
<b>Alternative</b>	N = Normal	A = Customized, proposal number needed
<b>Packaging (mm<sup>2</sup>)</b>	0 = Sample packaging C = Standard package, US fumigated pallet (1219*1016) 1 = Standard package, EU fumigated pallet (1200*800) 2 = Standard package, EU fumigated pallet (1500*800) E = Standard package, US plywood pallet (1219*1016) 5 = Standard package, EU plywood pallet (1200*800) 6 = Standard package, EU plywood pallet (1500*800)	

<b>Stroke Limit</b>	0 = Standard: Two micro switches cut off the actuator at end of stroke U = Virtual upper limit + physical lower limit	L = Physical upper limit + virtual lower limit 4 = Virtual upper limit + virtual lower limit
<b>Virtual Upper Limit (mm)</b>	XXXXX = Unit 0.1, 5 digits for stroke position. Default: max. stroke length (e.g. for 300, please enter 00300)	
<b>Virtual Lower Limit (mm)</b>	00000 = Unit 0.1, 5 digits for stroke position. Default: 0000 (e.g. for 10, please enter 00100)	
<b>Extending Speed (%)</b>	00 = Range from 01~100. Default: 00, meaning 100 duty cycle	
<b>Retracting Speed (%)</b>	00 = Range from 01~100. Default: 00, meaning 100 duty cycle	
<b>Reed Sensor 1 Function</b>	0 = No function 1 = Only extending allowed (signal: N.C) 2 = Only retracting allowed (signal: N.C) 3 = Stop movement when signal detected (signal: N.C)	4 = Only extending allowed (signal: N.O) 5 = Only retracting allowed (signal: N.O) 6 = Stop movement when signal detected (signal: N.O)
<b>Reed Sensor 2 Function</b>	0 = No function 1 = Only extending allowed (signal: N.C) 2 = Only retracting allowed (signal: N.C) 3 = Stop movement when signal detected (signal: N.C)	4 = Only extending allowed (signal: N.O) 5 = Only retracting allowed (signal: N.O) 6 = Stop movement when signal detected (signal: N.O)
<b>Duration of Soft Stop Before Upper Limit (s)</b>	05 = Unit 0.1, soft stop time, range from 0.1~3.0. Default: 05, meaning soft stop duration is 0.5 (e.g. for 2.5, enter 25)	
<b>Duration of Soft Stop Before Lower Limit (s)</b>	05 = Unit 0.1, soft stop time, range from 0.1~3.0. Default: 05, meaning soft stop duration is 0.5 (e.g. for 2.5, enter 25)	
<b>Soft Start - Extending (s)</b>	05 = Unit 0.1, soft start time, range from 0.1~3.0. Default: 05, meaning soft start duration is 0.5 (e.g. for 2.5, enter 25)	
<b>Soft Start - Retracting (s)</b>	05 = Unit 0.1, soft start time, range from 0.1~3.0. Default: 05, meaning soft start duration is 0.5 (e.g. for 2.5, enter 25)	
<b>Over-Current Mode Selection</b>	1 = Full stroke OCP	2 = 10-step stroke OCP
<b>Over-Current Protection Value - Extending (A)</b>	XXX = Unit 0.1, range from 000~actuator OCP value. (e.g. for 3.4, enter 034)	
<b>Over-Current Protection Value - Retracting (A)</b>	XXX = Unit 0.1, range from 000~actuator OCP value. (e.g. for 3.4, enter 034)	
<b>Over-Current Holding Time (s)</b>	XXX = Unit 0.1, range from 1~100. Default: 001, meaning over-current holding time is 0.1 (e.g. for 3.0, enter 030)	



<b>Output Signal - EOS Signal</b>	1 = With, at both ends
<b>Input Signal</b>	1 = Digital voltage signal
<b>Output Signal - Position Feedback / Bus Communication</b>	0 = Without
<b>Digital PWM Signal - at Fully Extended Position (%)</b>	XXX = Range from 0~100. Default value 090, meaning 90 (e.g. 55, enter 55)
<b>Digital PWM Signal - at Fully Retracted Position (%)</b>	XXX = Range from 0~100. Default value 010, meaning 10 (e.g. 55, enter 55)
<b>Analog Voltage Signal Output - at Fully Extended Position (V)</b>	XXX = Unit 0.1, range from 0~100. Default value 100, meaning 10.0 (e.g. for 9.4, enter 094)
<b>Analog Voltage Signal Output - at Fully Retracted Position (V)</b>	XXX = Unit 0.1, range from 0~100. Default value 000, meaning 0.0 (e.g. for 9.4, enter 094)
<b>Analog Current Signal Output - at Fully Extended Position (mA)</b>	XXX = Unit 0.1, range from 40~200. Default value 200, meaning 20 (e.g. 15, enter 150)
<b>Analog Current Signal Output - at Fully Retracted Position (mA)</b>	XXX = Unit 0.1, range from 40~200. Default value 040, meaning 4 (e.g. 8, enter 080)
<b>Alternative_#T_Advanced Synchronization</b>	0 = Without (1 actuator)
<b>Actuator ID</b>	1 = J1939 / Modbus / Primary (Synchronization master actuator)
<b>PGMB Version</b>	XXX = Not settable, reserved function

## Retracted Length (mm)

1. Calculate  $A+B+C = Y$
2. Retracted length needs to  $\geq \text{Stroke}+Y$

Important notice:

The motor cover might interfere with the customer's device when retracted length is between 250~318mm.

Please confirm with customer before placing order.

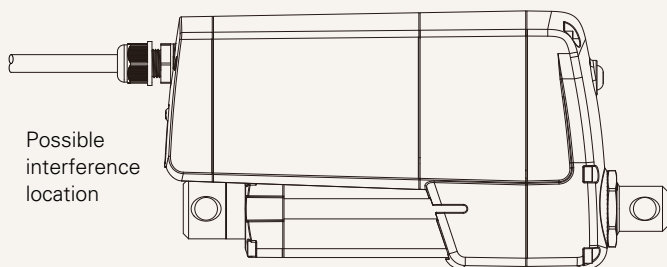

A.			
Front Attach.	Rear Attach.		
	1, 2, 5, 6	3, 4, 7, 8	9
1, 2, 5, 6	+200	+208	+205
3, 4, 7, 8	+207	+215	+212
9	+203	+211	+208
K	+220	+233	+230

C.	
Load and Speed	
B, C, D	+20

B.	
Stroke (mm)	Load & Speed Type (N)
	B, C, D
30~150	-
151~200	-
201~250	+10
251~300	+20
301~350	+30
351~400	+40
401~450	+50
451~500	+60
501~550	+70
551~600	+80
601~650	+90
651~700	+100
701~750	+110
751~800	+120
801~850	+130
851~900	+140
901~950	+150
951~1000	+160

## Rear Attachment (mm)

1 = #45 Steel, slotless, hole 10.2

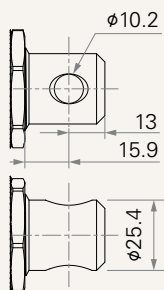

2 = #45 Steel, slotless, hole 12.8

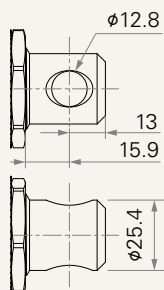

3 = #45 Steel, U clevis, slot 8.2, depth 15.0, hole 10.2

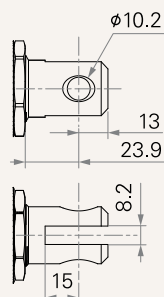

4 = #45 Steel, U clevis, slot 8.2, depth 15.0, hole 12.8

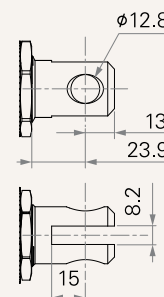

5 = Stainless Steel, slotless, hole 10.2

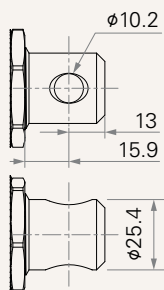

6 = Stainless Steel, slotless, hole 12.8

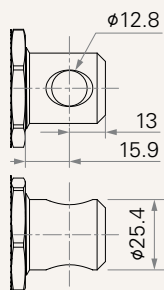

7 = Stainless Steel, U clevis, slot 8.2, depth 15.0, hole 10.2

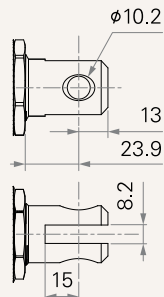

8 = Stainless Steel, U clevis, slot 8.2, depth 15.0, hole 12.8

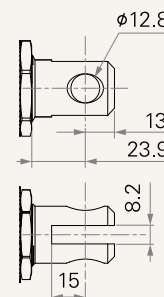

9 = #45 Steel, slotless, hole 16.2

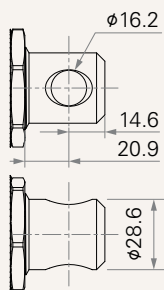

## Front Attachment (mm)

1 = #45 Steel, slotless, hole 10.2

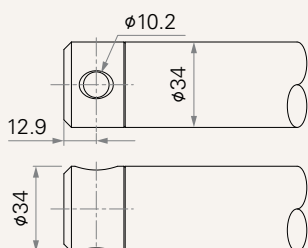

2 = #45 Steel, slotless, hole 12.8

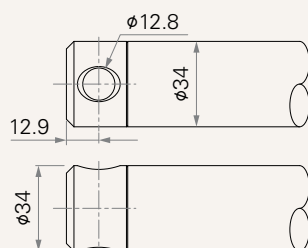

3 = #45 Steel, U clevis, slot 8.2, depth 15.0, hole 10.2

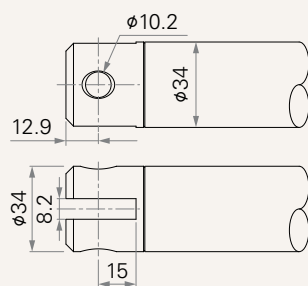

4 = #45 Steel, U clevis, slot 8.2, depth 15.0, hole 12.8

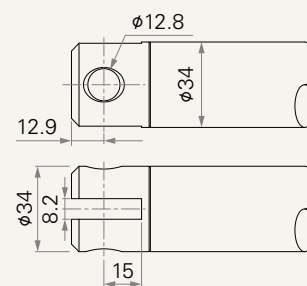

## Front Attachment (mm)

5 = Stainless Steel, slotless, hole 10.2

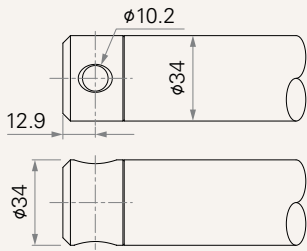

6 = Stainless Steel, slotless, hole 12.8

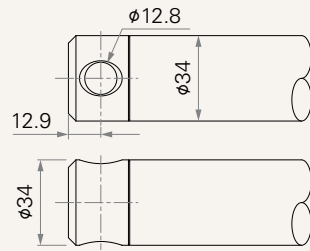

7 = Stainless Steel, U clevis, slot 8.2, depth 15.0, hole 10.2

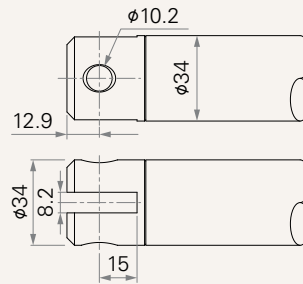

8 = Stainless Steel, U clevis, slot 8.2, depth 15.0, hole 12.8

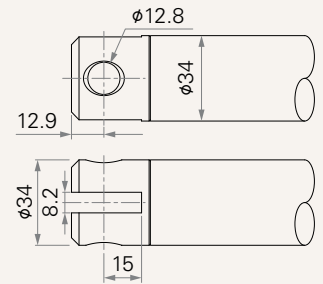

9 = #45 Steel, slotless, hole 16.2

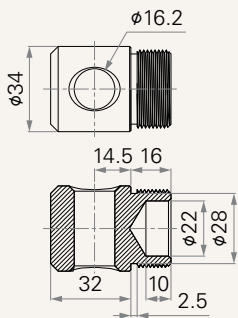

K = Rod end bearing, hole 12.8

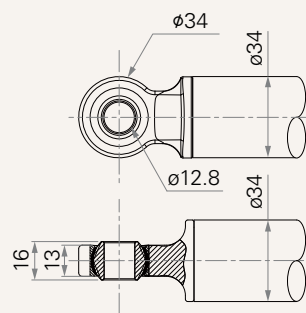

## Direction of Rear Attachment (Counterclockwise)

1 = 0°

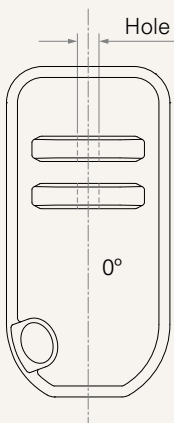

2 = 45°

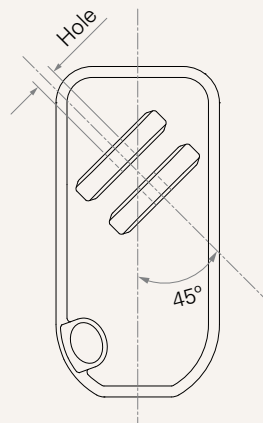

3 = 90°

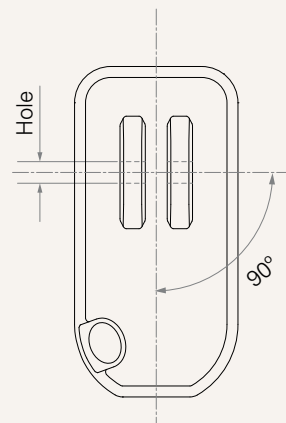

4 = 135°

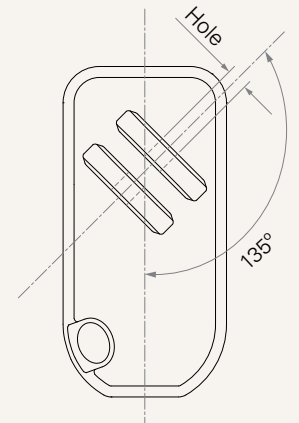

## Connector (mm)

01 = Tinned leads, unsheathed wire  
50, stripped wire 10



## Wire Definition

### Direct Cable Out, 1+1 Type: Military Connector (A1) + Molex 6P Connector (P2)

Port	Wire Color	AWG	Signal
A1	● RD	14	VDC +
	● BK	14	VDC -
	● GY	14	Resistance
	● BN	20	Ctrl - Extend
	● GY	20	Ctrl - Retract
	● OG	20	EOS - Extended
	● VT	20	EOS - Retracted
	● BK	20	Signal Ground
P2	Socket		For programming or wireless accessories.

\* Control motor movement: when VDC + wire is short circuit with Ctrl - Extend / Ctrl - Retract wire.

## Terms of Use

The user is responsible for determining the suitability of TiMOTION products for a specific application. TiMOTION products are subject to change without prior notice.