

MA2

series



Product Segments

- **Industrial Motion**

TiMOTION's MA2 series electric linear actuator was specifically designed for applications that face harsh working environments, requiring a heavy-duty construction and durability. Additionally, the MA2 has an optional T-Smart version. Embedded with a driver board, the MA2 allows for easy integration with a variety of control interfaces, eliminating the need for an external control box.

The MA2 is available in two T-Smart alternatives:

1) T-Smart Advanced

The actuator is controlled by an embedded PCBA, providing advanced functionality and real-time feedback. The T-Smart Advanced configuration allows for synchronization of up to 8 actuators, as well as providing accurate position feedback through a variety of options (Hall, Hall-Pot., PWM).

2) T-Smart Bus Communication

The actuator is controlled by the customer's control system, such as their ECU or PLC.

-SAE J1939: The standardized communication protocol commonly implemented in off-road vehicles and other industrial applications.

-Modbus: This is a serial communication protocol predominantly used in industrial automation and process control.

General Features

Max. load	8,000N (push); 4,000N (pull)
Max. speed at max. load	5.5mm/s
Max. speed at no load	52.5mm/s
Retracted length	≥ Stroke + 132mm
IP rating	IP69K
Certificate	UL73, EMC
Stroke	25~1000mm
Output Signals	External signal of actuator, mechanical Pot., NPN Hall sensor (5-36V input) * 2
Voltage	12/24/36/48V DC; 12/24/36/48V DC (thermal switch)
Operational temperature range	-40°C~+85°C
Operational temperature range at full performance	+5°C~+45°C
Manual drive	

Drawing

Standard Dimensions

1 = Single Cable
(mm)

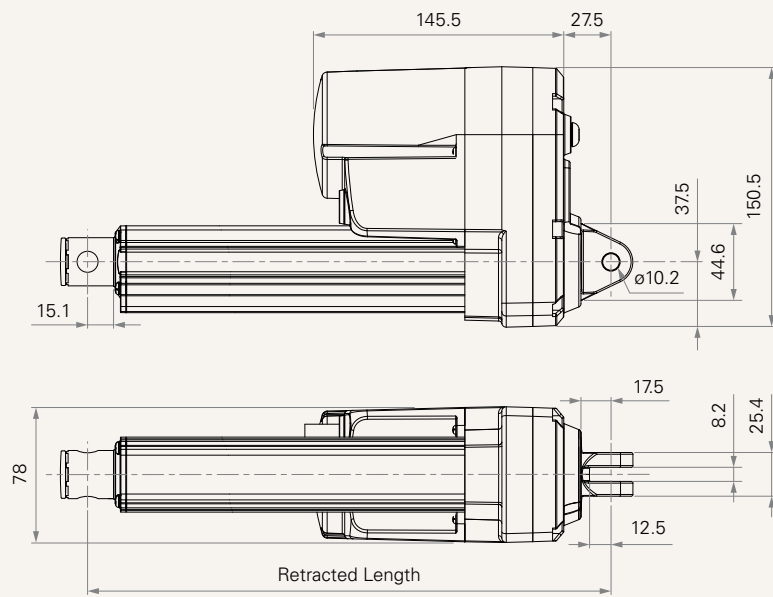

T-Smart Dimensions

3 = 3 Sockets with Extension Cable
(mm)

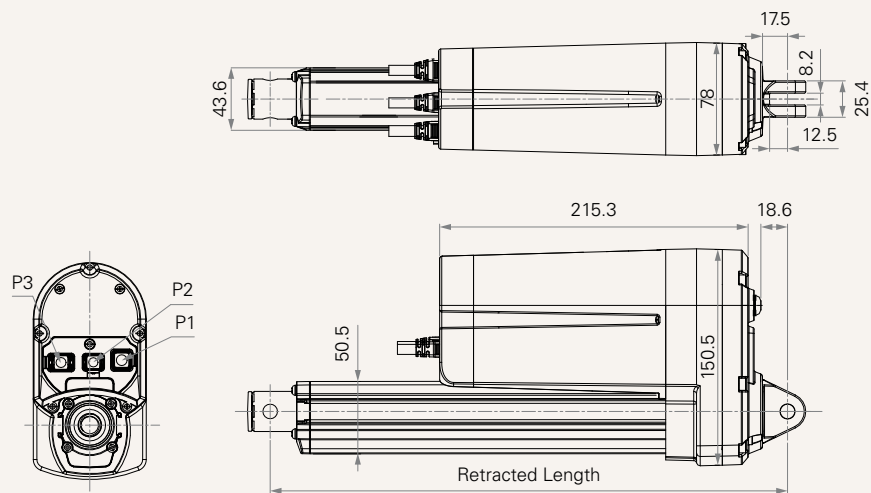

Drawing

T-Smart Dimensions
 T = 1+1 Type; A1 Direct Cable Out
 (mm)

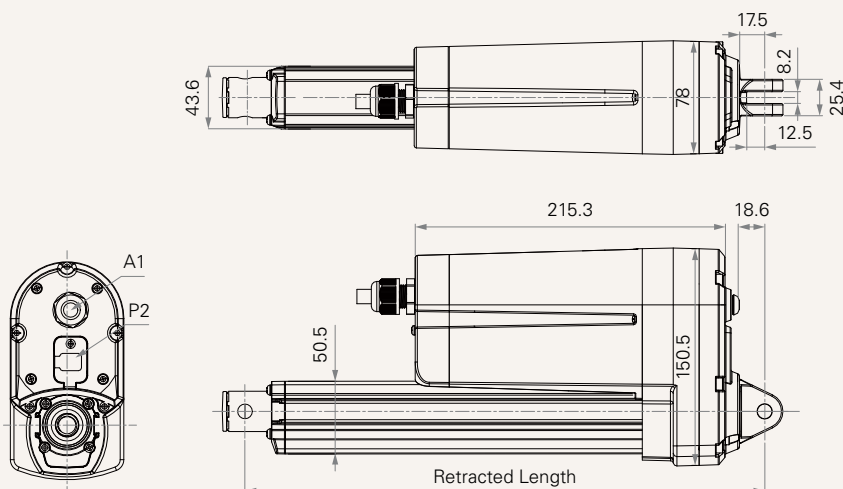

Load and Speed

CODE	Load (N)		Self Locking Force (N)	Duty Cycle	Typical Current (A)		Typical Speed (mm/s)	
	Push	Pull			Motor Brake	No Load 24VDC	With Load 24VDC	No Load 24VDC
Motor Speed (5200RPM)								
F	1000	1000	1300	25%	2.7	6.8	52.5	44.2
G	2000	2000	2600	25%	2.4	6.7	25.5	21.8
H	4000	4000	5200	25%	2.3	6.9	13.2	11.0
J	6000	4000	8000	25%	2.0	5.8	6.6	5.8
K	8000	4000	8000	10%	2.0	6.9	6.6	5.5

Note

- #B, C, D, E are only available in Type #N_Normal.
- Please refer to the approved drawing for the final authentic value.
- The current & speed in table are tested with 24V DC motor. With a 12V DC motor, the current is approximately twice the current measured in 24V DC. With a 36V DC motor, the current is approximately two-thirds the current measured in 24V DC. With a 48V DC motor, the current is approximately half the current measured in 24V DC. Speed will be similar for all the voltages.
- The current & speed in table are tested when the actuator is extending under push load.
- The current & speed in table and diagram are tested with a stable 24V DC power supply.
- Without load, noise level ≤ 78dBA (by TiMOTION test standard, ambient noise level ≤ 36dBA)
- Standard stroke: Min. 25mm, Max. please refer to the table below.
- Tolerance: fully extended length & retracted length ± 3mm.

CODE	Load (N)	Max Stroke (mm)
F	≤ 1000	1000
G	≤ 2000	800
H, J	≤ 6000	600
K	≤ 8000	320

* Max. stroke with mechanical Pot: 570mm.

Performance Data (24V DC Motor)

Motor Speed (5200RPM)

Speed vs. Load

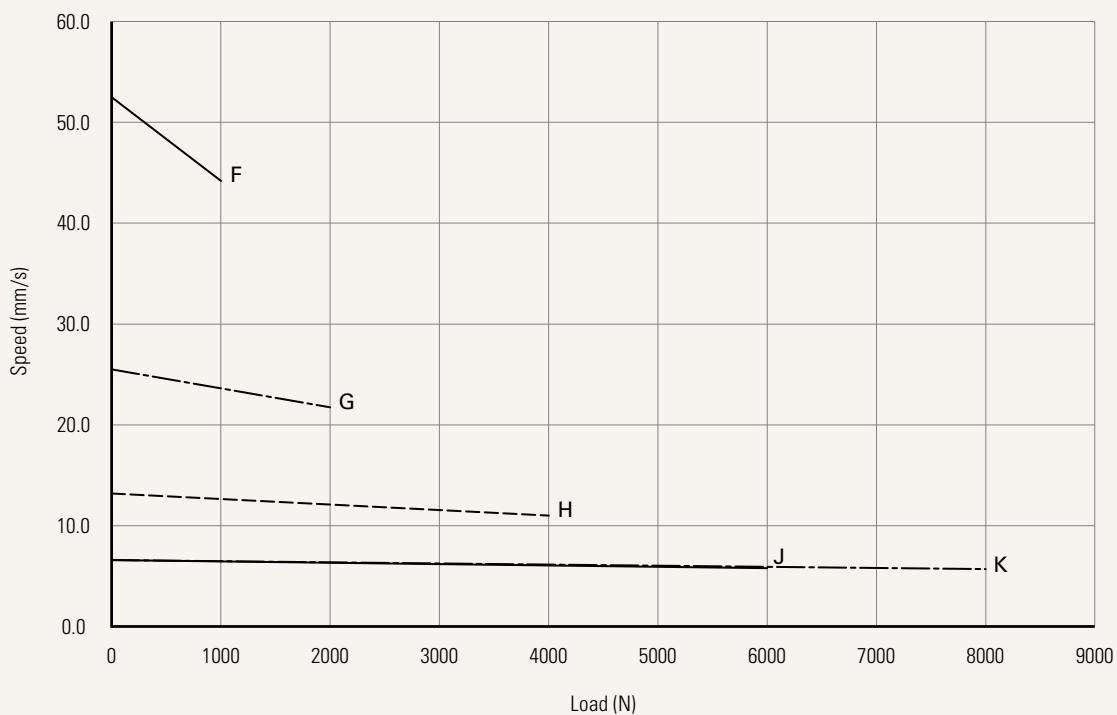

Current vs. Load

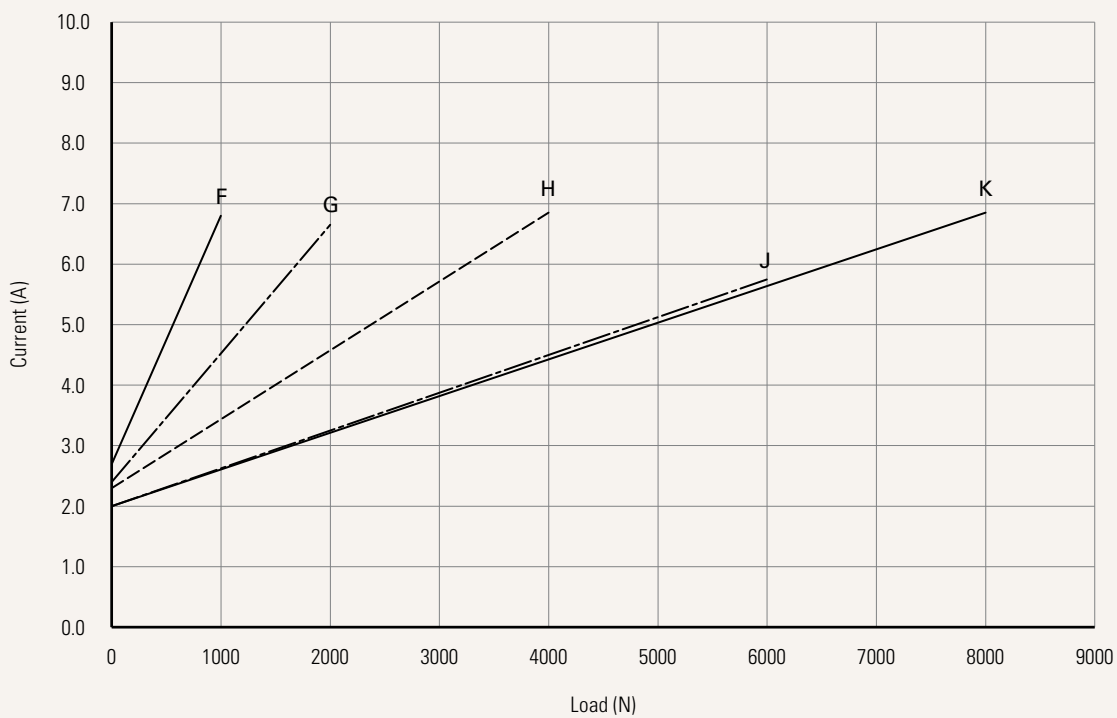

Type See page 2-3	N = Normal	T = T-Smart
Voltage	1 = 12V DC 2 = 24V DC 3 = 36V DC 4 = 48V DC	5 = 24V DC, thermal switch 6 = 12V DC, thermal switch 7 = 36V DC, thermal switch 8 = 48V DC, thermal switch
Load and Speed	See page 3	
Stroke (mm)	See page 3	
Retracted Length (mm)	See page 7	
Rear Attachment (mm) See page 8	1 = Aluminum, U clevis, slot 8.2, depth 12.5, hole 10.2 2 = Aluminum, U clevis, slot 8.2, depth 15.0, hole 10.2 3 = Aluminum, U clevis, slot 8.2, depth 15.0, hole 12.8	4 = Aluminum, U clevis, slot 8.2, depth 15.0, hole 12.2 S = Stainless steel SUS304 (lost-wax casting), slot 8.2, depth 15, hole 10.2
Front Attachment (mm) See page 8-9	1 = Steel, inner tube with punching hole and seal plug, hole 10.2 2 = Steel, inner tube with punching hole and seal plug, hole 12.2 3 = Steel, inner tube with punching hole and seal plug, hole 12.8 4 = Aluminum, U clevis, slot 8.2, depth 15.0, hole 10.2	5 = Aluminum, U clevis, slot 8.2, depth 15.0, hole 12.2 6 = Aluminum, U clevis, slot 8.2, depth 15.0, hole 12.8 7 = Stainless Steel 316L, slotless, hole 10.2 8 = Stainless Steel 316L, slotless, hole 12.2 9 = Stainless Steel 316L, slotless, hole 12.8 K = Rod end bearing, hole 12.8
Direction of Rear Attachment (Counterclockwise) See page 9	1 = 0°	3 = 90°
Function of Limit Switches See page 10-12	1 = Two limit switches cut off the actuator at EOS 2 = Two limit switches cut off the actuator at EOS + third one in between sends signal 3 = Two limit switches send signal at EOS	6 = Two limit switches cut off the actuator and send signal at EOS T = Two limit switches send signal at end of stroke to embedded PCBA (T-Smart dedicated option)
External Signal of Actuator	0 = Without 3 = Reed switch * 1, tinned leads (NO, signal to customer control system) 4 = Reed switch * 2, tinned leads (NO, signal to customer control system) C = Reed switch * 2, Molex 6p (T-Smart dedicated option, normal open)	
Output Signal See page 10-12	0 = Without 1 = Mechanical pot.	N = NPN Hall sensor (5-36V input) * 2 T = Hall sensor * 2, signals to embedded PCBA (T-Smart dedicated option)
IP Rating	1 = Without 2 = IP54	3 = IP66 6 = IP66M 8 = IP69K



Cable Exit See page 2-3	1 = Single cable 3 = 3 sockets with extension cable (P1, P2, P3) (T-Smart dedicated option) T = Direct cable out, 1+1 type: Military connector (A1) + Molex 6P connector (P2) (T-Smart dedicated option)
A1 / P1 Connector (mm) See page 9	01 = Tinned leads, unsheathed wire 50, stripped wire 10
A1 / P1 Cable Length (mm)	XXXX = Input 4 digital number directly, range 0-5000, multiples of 100 (e.g. 500, enter 0500)
P2 Connector (mm)	00 = Without OP = Rubber seal plug (T-Smart dedicated option)
P2 Cable Length (mm)	0000 = Without
P3 Connector (mm)	00 = Without 01 = Tinned leads, unsheathed wire 50, stripped wire 10 (T-Smart dedicated option)
P3 Cable Length (mm)	0000 = Without XXXX = Input 4 digital number directly, range 0-5000, multiples of 100 (e.g. 500, enter 0500) (T-Smart dedicated option)
Alternative	N = Normal T = Advanced J = SAE J1939 (J1939 default, transmission rate 250Kbps, proposal #PF22018) K = SAE J1939 (transmission rate 500Kbps, proposal #DS23021) M = Modbus RTU (proposal #PF22082)
Packaging (mm²)	0 = Sample packaging C = Standard package, US fumigated pallet (1219*1016) 1 = Standard package, EU fumigated pallet (1200*800) 2 = Standard package, EU fumigated pallet (1500*800) E = Standard package, US plywood pallet (1219*1016) 5 = Standard package, EU plywood pallet (1200*800) 6 = Standard package, EU plywood pallet (1500*800)

Retracted Length (mm)

1. Calculate $A+B+C = Y$
2. Retracted length needs to \geq Stroke + Y

A.		
Front Attachment	Rear Attachment	
	1	2, 3, 4, S
1, 2, 3	+132	+135
4, 5, 6	+161	+164
7, 8, 9	+150	+153
K	+178	+181

C.	
Output Signal	
0, N, P	-
1	+20

B.	
Stroke (mm)	Load & Speed Type (N)
	F, G, H, J, K
25~150	-
151~200	-
201~250	+10
251~300	+20
301~350	+30
351~400	+40
401~450	+50
451~500	+60
501~550	+70
551~600	+80
601~650	+90
651~700	+100
701~750	+110
751~800	+120
801~850	+130
851~900	+140
901~950	+150
951~1000	+160

Rear Attachment (mm)

1 = Aluminum, U clevis, slot 8.2, depth 12.5, hole 10.2

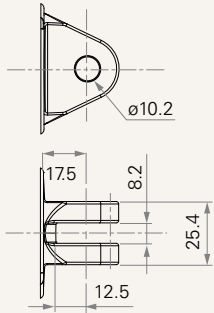

2 = Aluminum, U clevis, slot 8.2, depth 15.0, hole 10.2

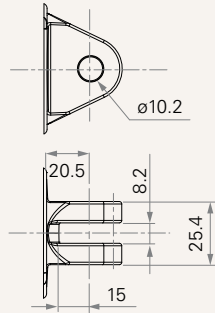

3 = Aluminum, U clevis, slot 8.2, depth 15.0, hole 12.8

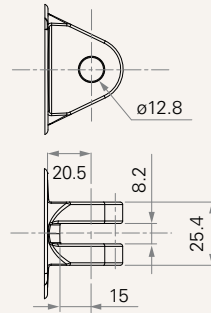

4 = Aluminum, U clevis, slot 8.2, depth 15.0, hole 12.2

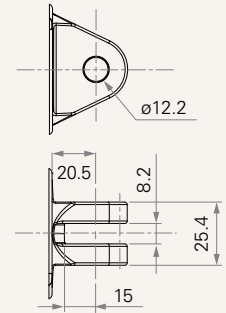

S = Stainless steel SUS304 (lost-wax casting), slot 8.2, depth 15, hole 10.2

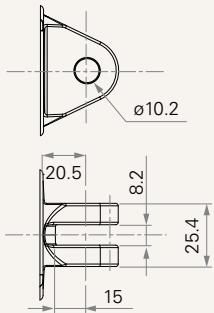

Front Attachment (mm)

1 = Steel, inner tube with punching hole and seal plug, hole 10.2

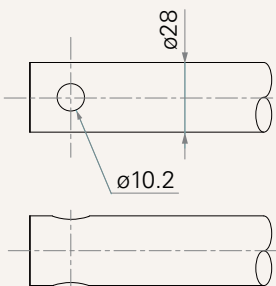

2 = Steel, inner tube with punching hole and seal plug, hole 12.2

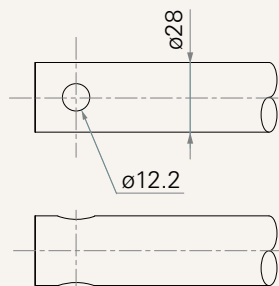

3 = Steel, inner tube with punching hole and seal plug, hole 12.8

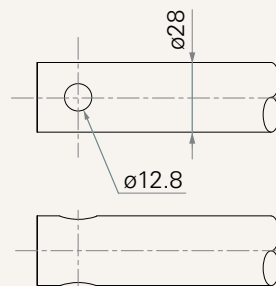

4 = Aluminum, U clevis, slot 8.2, depth 15.0, hole 10.2

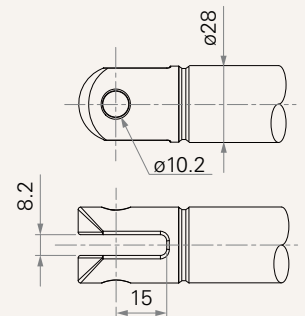

5 = Aluminum, U clevis, slot 8.2, depth 15.0, hole 12.2

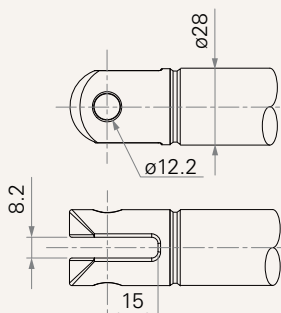

6 = Aluminum, U clevis, slot 8.2, depth 15.0, hole 12.8

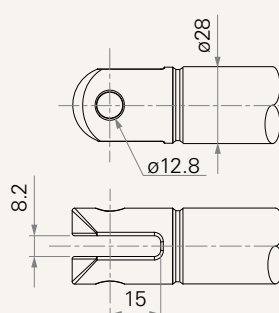

7 = Stainless Steel 316L, slotless, hole 10.2

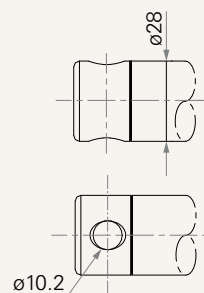

8 = Stainless Steel 316L, slotless, hole 12.2

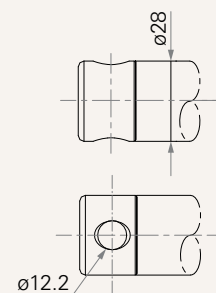

Front Attachment (mm)

9 = Stainless Steel 316L, slotless,
hole 12.8

K = Rod end bearing, hole 12.8

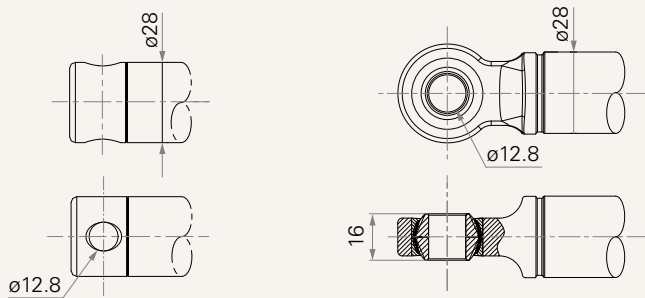

Direction of Rear Attachment (Counterclockwise)

1 = 0°

3 = 90°

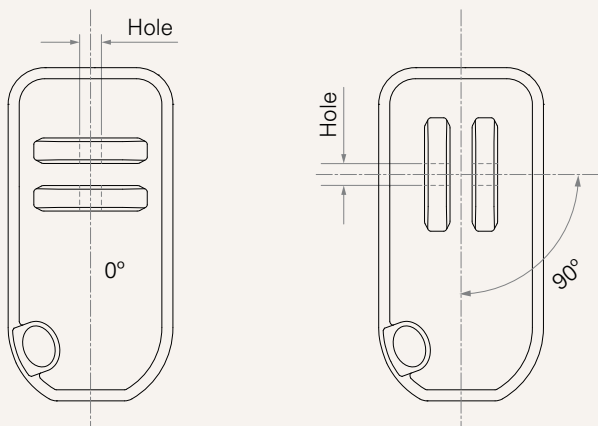

Connector (mm)

01 = Tinned leads, unsheathed wire
50, stripped wire 10

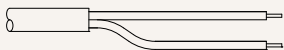

Wire Definition

#N_Normal

Port	Function of Limit Switches	Wire Color	Wire Gauge (AWG)	Output Signal		
				0. Without	1. Mechanical Pot.	N. Hall Sensor * 2
A1	1 Two limit switches cut off the actuator at end of stroke	● RD	14	EXT+	EXT+	EXT+
		● BK	14	RET+	RET+	RET+
		● RD	20	-	POT-out	+5V
		○ WH	20	-	+5V (POT)	S1
		● BK	20	-	GND	GND
		● BU	20	-	-	S2
		● BN	20	-	-	-
		● GY	20	-	-	-
		● OG	20	-	-	-
		● VT	20	-	-	-
	2 Two limit switches cut off the actuator at EOS + third one in-between sends signal	● RD	14	EXT+	EXT+	EXT+
		● BK	14	RET+	RET+	RET+
		● RD	20	-	-	Hall-Vin (+5V)
		○ WH	20	3rd LS pin1	3rd LS pin1	S1
		● BK	20	3rd LS pin2	POT-GND	GND
		● BU	20	-	3rd LS pin2	S2
		● BN	20	-	POT-Vin (+5V)	3rd LS pin1
		● GY	20	-	-	-
		● OG	20	-	POT-Vout	3rd LS pin2
		● VT	20	-	-	-
	3 Two limit switches send signal at end of stroke	● RD	14	EXT+	EXT+	EXT+
		● BK	14	RET+	RET+	RET+
		● RD	20	EOS-COM	EOS-COM	+5V
		○ WH	20	EOS-extended	EOS-extended	S1
		● BK	20	-	POT-GND	GND
		● BU	20	EOS-retracted	EOS-retracted	S2
		● BN	20	-	POT-Vin (+5V)	EOS-extended
		● GY	20	-	-	-
		● OG	20	-	POT-Vout	EOS-retracted
		● VT	20	-	-	EOS-COM
	4 Two limit switches send signal at end of stroke + third one in-between sends signal	● RD	14	EXT+	EXT+	EXT+
		● BK	14	RET+	RET+	RET+
		● RD	20	EOS-COM	EOS-COM	Hall-Vin (+5V)
		○ WH	20	EOS-extended	EOS-extended	S1
		● BK	20	3rd LS pin1	3rd LS pin1	Hall-GND
		● BU	20	EOS-retracted	EOS-retracted	S2
● BN		20	-	POT-Vin (+5V)	EOS-extended	
● GY		20	-	-	3rd LS pin1	
● OG		20	-	POT-Vout	EOS-retracted	
● VT		20	-	POT-GND	EOS-COM	
6 Two limit switches cut off the actuator and send signal at EOS	● RD	14	EXT+	-	-	
	● BK	14	RET+	-	-	
	● RD	20	-	-	-	
	○ WH	20	EOS-extended	-	-	
	● BK	20	EOS-retracted	-	-	
	● BU	20	-	-	-	
	● BN	20	-	-	-	
	● GY	20	-	-	-	
	● OG	20	-	-	-	
	● VT	20	-	-	-	

Wire Definition

#T_T-Smart

3 Sockets with Extension Cable (P1, P2, P3) (T-Smart Dedicated Option)

Port	Wire Color	AWG	Signal
P1	● RD	14	+Vcc
	● BK	14	Power ground
P2	● RD	20	For programming or wireless accessories.
	○ WH	20	
	● BU	20	
	● BK	20	
	● BN	20	
	● GY	20	
P3	● BN	20	Ctrl - Extend
	● GY	20	Ctrl - Retract
	● OG	20	EOS-extended
	● YE	20	EOS-retracted
	○ WH	20	Hall-Pot. / Hall A / Commu. A
	● BU	20	PWM / Hall B / Commu. B
	● RD	20	Vaux. (Power supply to controller)
	● BK	20	Signal ground

* Control motor movement: when Vaux wire is short circuit with Ctrl-Extend / Ctrl-retract wire.

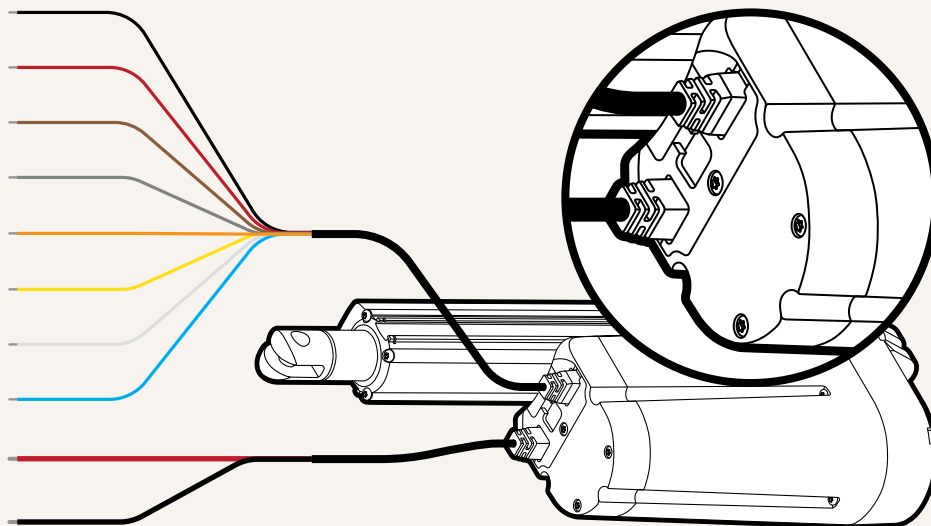

Wire Definition

#T_T-Smart

Direct Cable Out, 1+1 Type: Military Connector (A1) + Molex 6P Connector (P2) (T-Smart Dedicated Option)

Port	Wire Color	AWG	Signal
A1	● RD	14	+Vcc
	● BK	14	Power ground
	● BN	20	Ctrl - Extend
	● GY	20	Ctrl - Retract
	● OG	20	EOS-extended
	● YE	20	EOS-retracted
	○ WH	20	Hall-Pot. / Hall A / Commu. A
	● BU	20	PWM / Hall B / Commu. B
	● BK	20	Signal ground
	P2	● RD	20
○ WH		20	
● BU		20	
● BK		20	
● BN		20	
● GY		20	

* Control motor movement: when Vcc wire is short circuit with Ctrl-Extend / Ctrl-retract wire.

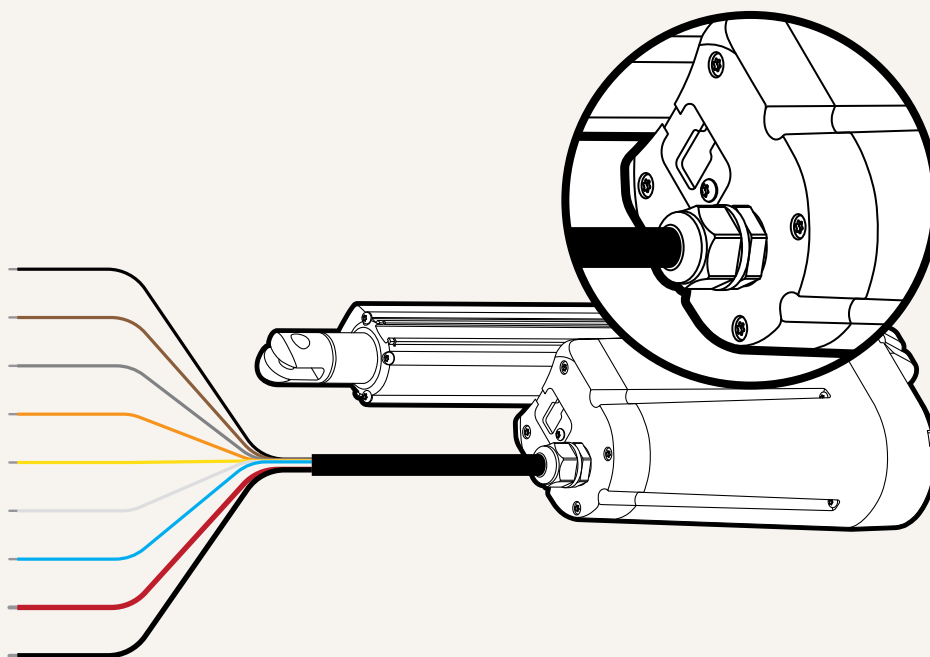

Terms of Use

The user is responsible for determining the suitability of TiMOTION products for a specific application. TiMOTION products are subject to change without prior notice.