

VN1

series

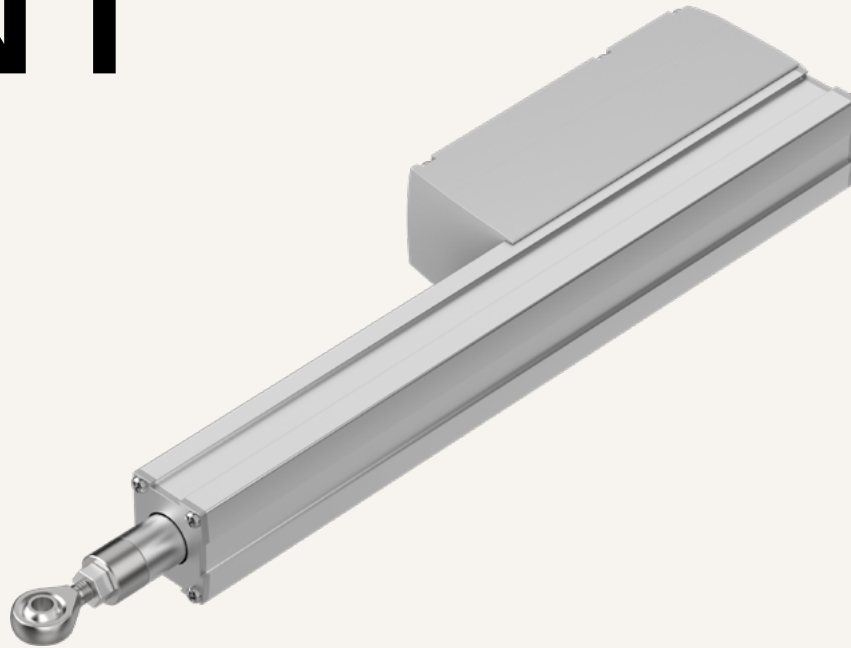

Product Segments

- **Industrial Motion**

The VN1 series linear actuator was specifically designed for ventilation applications to help remove smoke, heat, and toxic gases from the building quickly in the event of a fire. It was also designed to create a minimum smoke layer in the lower parts of the room. The VN1 is made of high-quality aluminum, suitable for applications like fall-through protection systems and greenhouses. The VN1 is equipped with either a 12V or 24V DC motor. The AC version of the VN1 is equipped with a built-in SMPS which allows the supply of alternating current.

Furthermore, the VN1 has an optional **T-Smart** version. Embedded with a TiMOTION driver board, the VN1 eliminates the need of an external control box. The VN1 T-Smart version allows for the synchronization of up to 8 actuators with an integrated controller, allowing for coordinated and efficient movement.

Besides, its T-Smart version is compatible with TiMOTION's software program PGVN, providing the user autonomy to adjust parameters such as speed, stroke limits, soft stop, soft start, and more.

General Features

Max. load	3,500N (push); 2,000N (pull)
Max. speed at max. load	3.8mm/s
Max. speed at no load	13mm/s
Retracted length	≥ 187mm (DC version, w/o T-Smart; depending on chosen options); ≥ 414mm (AC version, w/o T-Smart; depending on chosen options)
IP rating	IP66
Stroke	20~500mm
Output signals	NPN Hall sensors, Embedded Hall sensor*2 for T-Smart
Options	Safety nut, window seal mechanism, T-Smart
Voltage	12/24V DC; 12/24V DC (PTC); 100~240V AC (50Hz)
Color	Black, grey
Operational temperature range	-15°C~+50°C
Operational temperature range at full performance	+5°C~+45°C

Drawing

Dimensions
with DC Voltage
(mm)

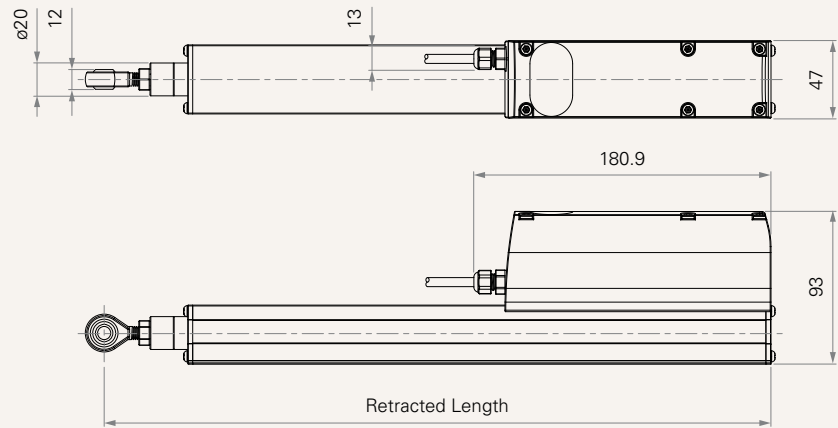

Dimensions
with AC Voltage
(mm)

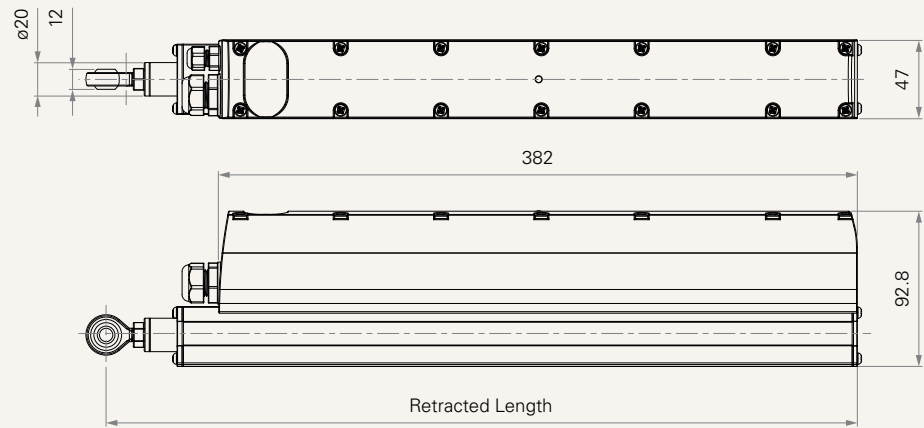

Load and Speed - DC Motor

CODE	Load (N)		Self Locking Force (N)	Duty Cycle	24V DC				*T-Smart Usability	12V DC				
	Push	Pull			Typical Current (A)	Typical Speed (mm/s)		Typical Current (A)		Typical Speed (mm/s)		*T-Smart Usability		
						No Load	With Load			No Load	With Load			
Motor Speed (5200RPM)														
B	500	500	2500	10% (2 min. on / 18 min. off)	1.7	2.0	7.2	7.2	Y	3.7	4.0	7.1	6.7	N
C	1000	1000	3500	10% (2 min. on / 18 min. off)	1.7	2.4	4.5	4.3	Y	3.7	4.8	4.2	4.0	N
D	2000	2000	2500	10% (2 min. on / 18 min. off)	1.7	3.5	7.2	5.8	N	3.7	8.0	7.1	5.5	N
E	3500	2000	3500	10% (2 min. on / 18 min. off)	1.7	4.2	4.5	3.4	N	3.7	10.0	4.2	3.1	N
F	1600	1600	3500	10% (2 min. on / 18 min. off)	1.7	3.7	9.0	8.5	N	3.7	8.5	8.6	8.2	N

Note

- Please refer to the approved drawing for the final authentic value.
- This self-locking force level is reached only when a short circuit is applied on the terminals of the motor. All the TiMOTION control boxes have this feature built-in.
- The current & speed in table are tested with 24V DC motor. With a 12V DC motor, the current is approximately twice the current measured in 24V DC; speed will be similar for both voltages. If choosing the voltage option #U, its performance is as the same as 24V DC motor.
- The current & speed in table are tested when the actuator is extending under push load.
- The current & speed in table and diagram are tested with a stable 24V,12V DC power supply.
- Without load, noise level ≤ 58 dBA (by TiMOTION test standard, ambient noise level ≤ 36 dBA)
- Standard stroke: Min. ≥ 20mm, Max. please refer to the table below.

CODE	Load (N)	Max Stroke (mm)
E	≤ 3500	300
D, F	≤ 2000	450
B, C	≤ 1000	500

Load and Speed - AC Motor

CODE	Load (N)		Self Locking Force (N)	Duty Cycle	220V AC				*T-Smart Usability
	Push	Pull			Typical Current (A)		Typical Speed (mm/s)		
					No Load	With Load	No Load	With Load	
Motor Speed (5200RPM)									
B	500	500	2500	10% (2 min. on / 18 min. off)	0.60	0.6	9.6	8.2	Y
C	1000	1000	3500	10% (2 min. on / 18 min. off)	0.60	0.6	6.0	5.1	Y
D	2000	2000	2500	10% (2 min. on / 18 min. off)	0.60	1.0	9.6	6.4	N
E	3500	2000	3500	10% (2 min. on / 18 min. off)	0.60	1.2	6.0	3.8	N
F	1600	1600	3500	10% (2 min. on / 18 min. off)	0.60	0.6	13.0	9.1	N

Note

- 1 Please refer to the approval drawing for the final authentic value. The load speed is tested during 220 VAC, 50Hz condition.
- 2 This self-locking force level is reached only when a short circuit is applied on the terminals of the motor. All the TiMOTION control boxes have this feature built-in.
- 3 The current & speed in table are tested when the actuator is extending under push load.
- 4 The current & speed in table and diagram are tested with a 220VAC, 50Hz power supply.
- 5 Without load, noise level ≤ 58 dBA (by TiMOTION test standard, ambient noise level ≤ 36 dBA)
- 6 Standard stroke: Min. ≥ 20 mm, Max. please refer to the table below.

CODE	Load (N)	Max Stroke (mm)
E	≤ 3500	300
D, F	≤ 2000	450
B, C	≤ 1000	500

Performance Data (24V DC Motor)

Motor Speed (5200RPM)

Speed vs. Load

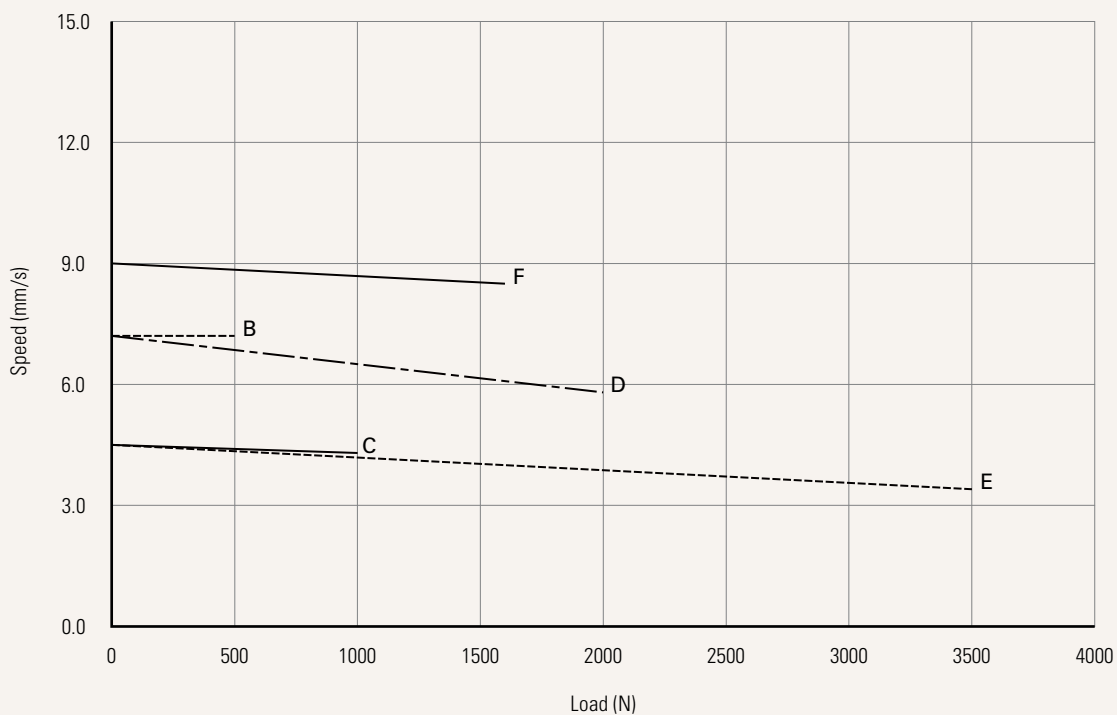

Current vs. Load

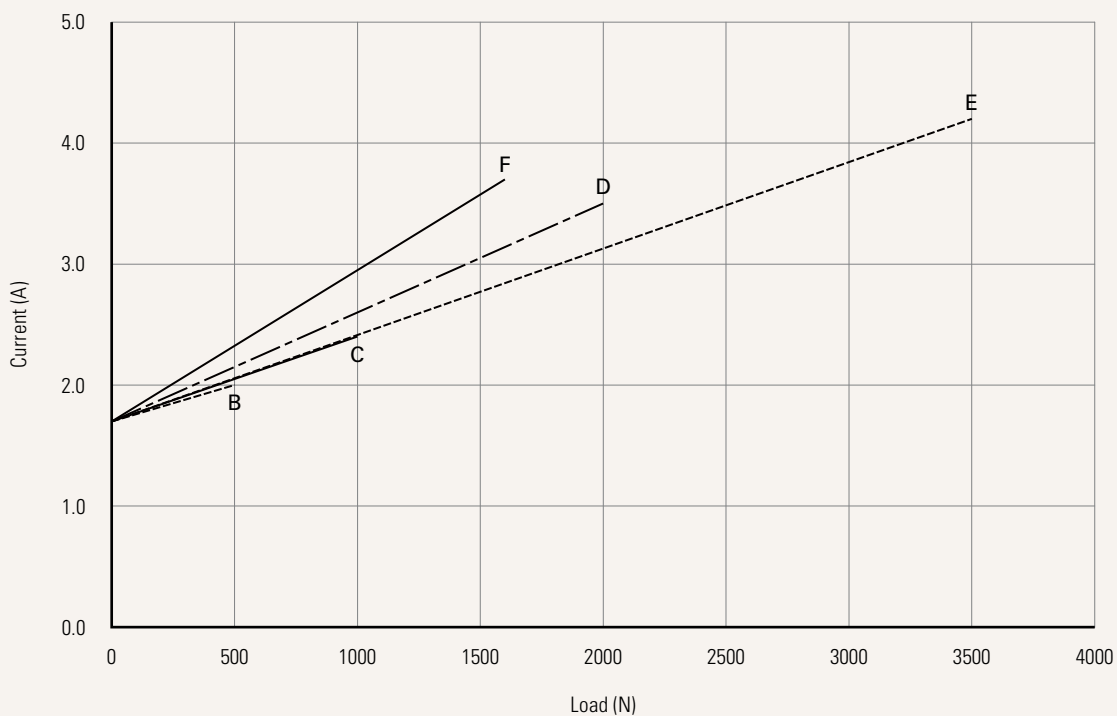

Performance Data (12V DC Motor)

Motor Speed (5200RPM)

Speed vs. Load

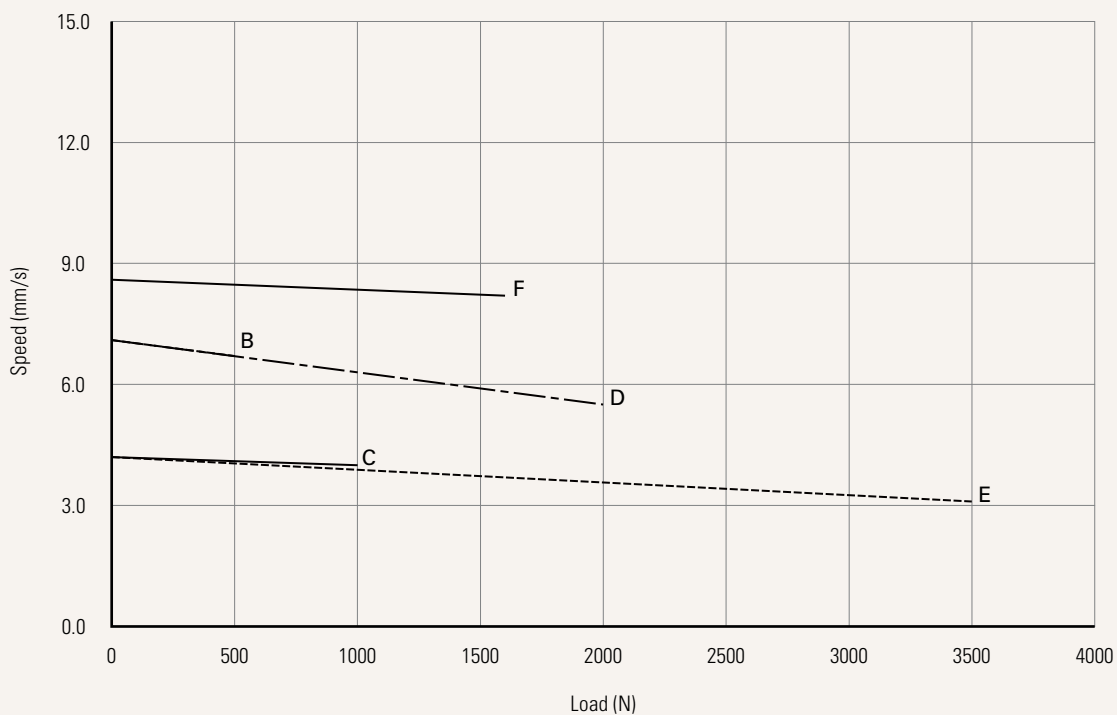

Current vs. Load

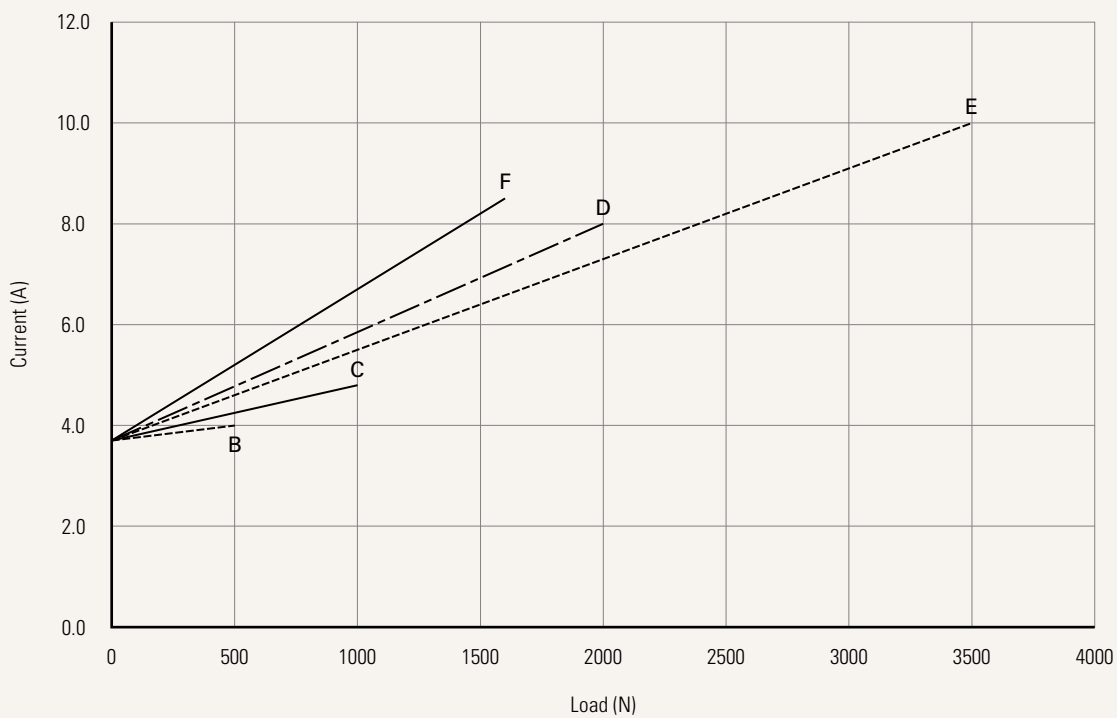

Performance Data (220V AC Motor)

Motor Speed (5200RPM)

Speed vs. Load

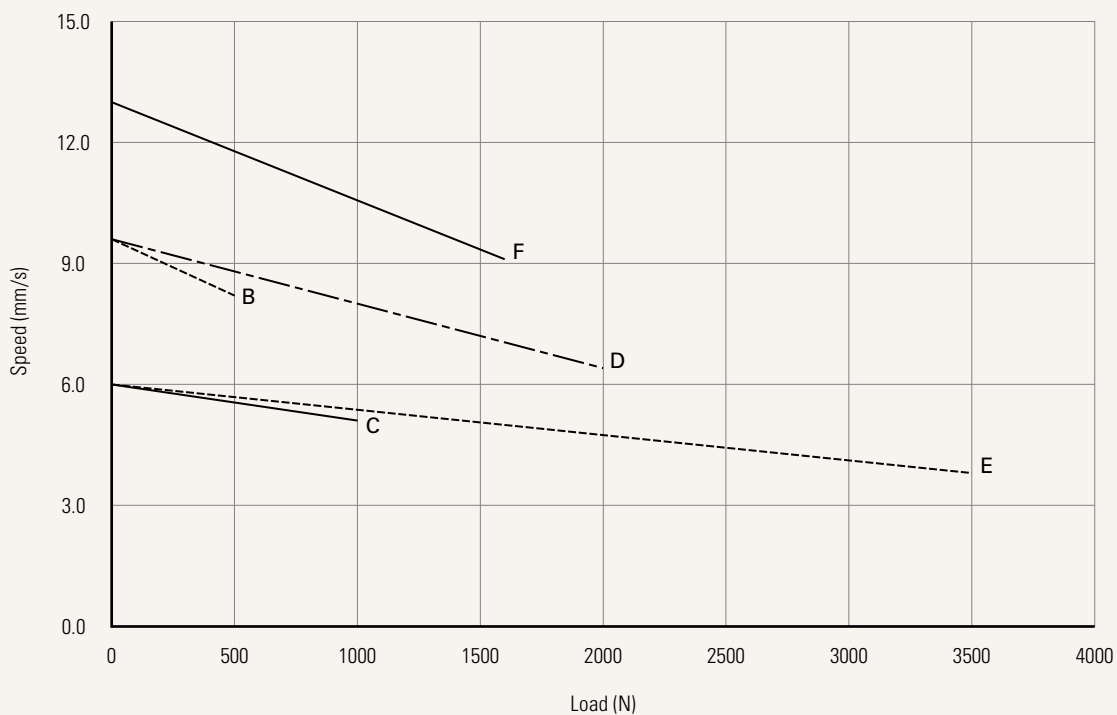

Current vs. Load

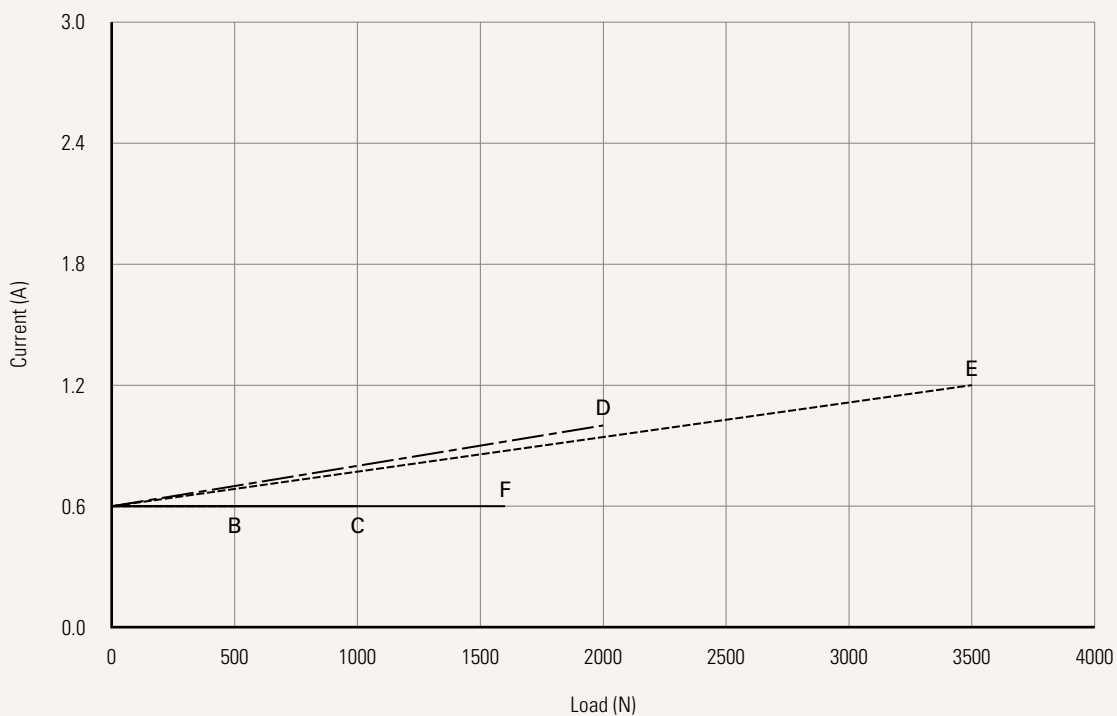

Type	N = Normal	T = T-Smart	
Voltage	1 = 12V DC 2 = 24V DC	5 = 24V DC, PTC 6 = 12V DC, PTC	U = 100~240V AC (50 Hz)
Load and Speed	See page 3-4		
Stroke (mm)	See page 3-4		
Retracted Length (mm)	See page 9		
Rear Attachment (mm)	0 = Without (must choose outer tube adjustable clamping block)		
Outer Tube Adjustable Clamping Block	1 = Hole M8	2 = Hole ø8	
	See page 9		
Mounting Bracket	0 = Without		
Front Attachment (mm)	B = Rod end bearing, hole 8.0 C = Rod end bearing, hole 10.0 1 = Aluminum, slotless, hole 6.4 2 = Aluminum, slotless, hole 8.0	3 = Aluminum, slotless, hole 10.0 7 = Aluminum, U clevis, slot 6.2, depth 16.0, hole 6.4 8 = Aluminum, U clevis, slot 6.2, depth 16.0, hole 8.0 9 = Aluminum, U clevis, slot 6.2, depth 16.0, hole 10.0	
	See page 10		
Direction of Rear Attachment (Counterclockwise)	0 = Without (without rear attachment)	1 = 0°	3 = 90°
	See page 10		
Function of Limit Switches	1 = Two micro switches cut off the actuator at end of stroke (EOS) 3 = Two micro switches send signal at end of stroke 6 = Two micro switches cut off the actuator at EOS + third micro switch at lower limit as window closure indicator		
Window Seal Mechanism	0 = Without	1 = With	
Special Function of Spindle Subassembly	0 = Without	S = Safety nut (push direction)	
Output Signal	0 = Without N = NPN Hall sensor*2	E = Embedded Hall sensor*2 for T-Smart, no Hall signal output (T-smart dedicated option)	
IP Rating	1 = Without	2 = IP54	3 = IP66
Load Type	T = Push	P = Pull	
Position of Cable Exit	B = Position B	C = Position C	
P1 Cable Exit	00 = DC (without cable) 01 = AC (EU), cable color 428C	02 = AC (US), cable color 428C	
P1 Cable Length (mm)	0500 = 500 1000 = 1000	1500 = 1500 2000 = 2000	5000 = 5000
P2 Cable Exit	00 = AC normal type (without cable) 01 = DC (standard), cable color 428C	03 = AC T-Smart specified, cable color 428C	
P2 Cable Length (mm)	0000 = Without cable 0500 = 500	1000 = 1000 1500 = 1500	2000 = 2000 5000 = 5000
Alternative	N = Normal	P = Parallel	

Retracted Length (mm)

1. Calculate $A+B = Y$
2. Retracted length needs to $\geq \text{Stroke}+Y$, and also \geq value stated in the table below

A. Attachments and Adjustable Clamping Block

Front Attachment Outer Tube Adjustable Clamping Block

B	+206
C	+212
1, 2, 3	+169
7, 8, 9	+182

B. Stroke (mm)

20~150	-
151~200	+2
201~250	+2
251~300	+2
301~350	+12
351~400	+22
401~450	+32
451~500	+42

The retracted length calculated above must be equal to or longer than the minimum value stated below

When Choosing Outer Tube Adjustable Clamping Block

Voltage	DC		AC	
	Normal	T-Smart	Normal	T-Smart
B	218	308	438	438
C	224	314	444	444
1, 2, 3	187	277	417	417
7, 8, 9	194	284	414	414

Outer Tube Adjustable Clamping Block

1 = Hole M8

2 = Hole $\varnothing 8$

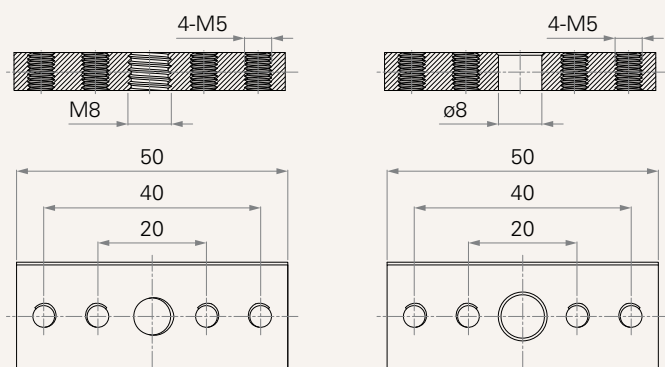

Clamping block Assembly dimension

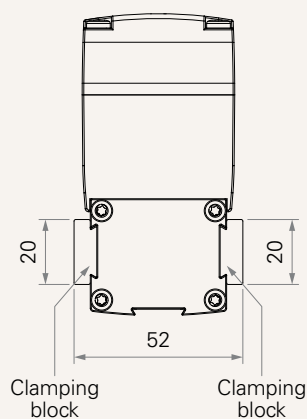

Front Attachment (mm)

B = Rod end bearing, hole 8.0

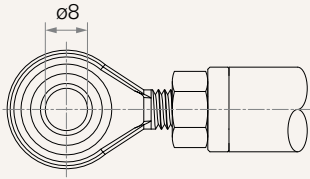

C = Rod end bearing, hole 10.0

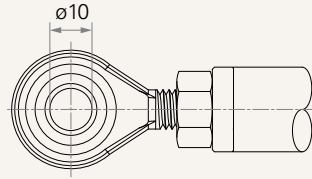

1 = Aluminum, slotless, hole 6.4

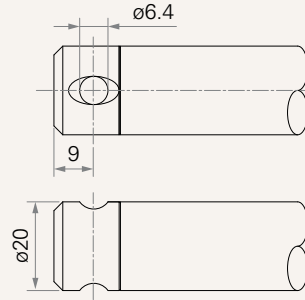

2 = Aluminum, slotless, hole 8.0

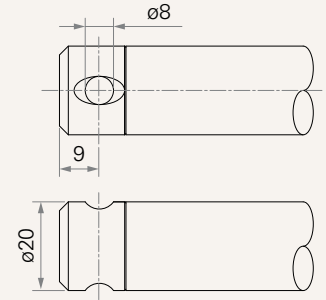

3 = Aluminum, slotless, hole 10.0

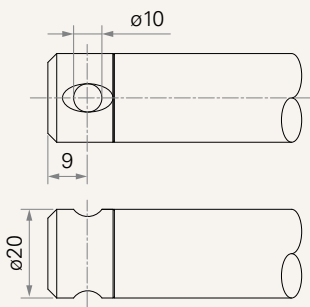

7 = Aluminum, U clevis, slot 6.2, depth 16.0, hole 6.4

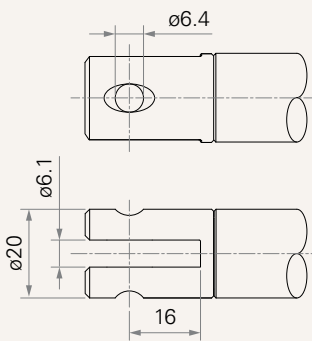

8 = Aluminum, U clevis, slot 6.2, depth 16.0, hole 8.0

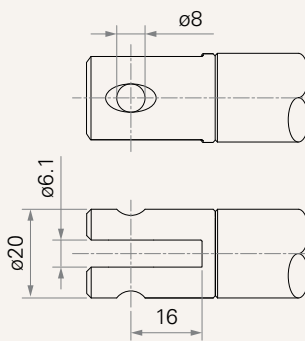

9 = Aluminum, U clevis, slot 6.2, depth 16.0, hole 10.0

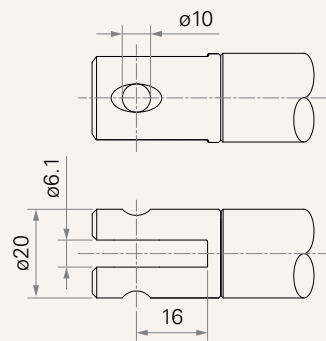

Direction of Rear Attachment (Counterclockwise)

0 = Without (without rear attachment)

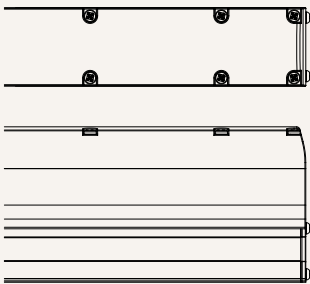

1 = 0°

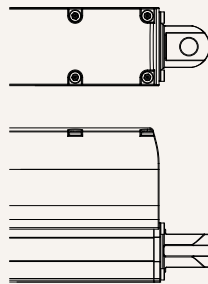

3 = 90°

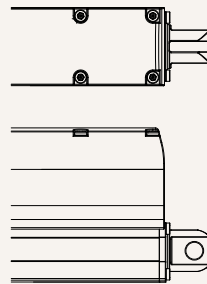

Terms of Use

The user is responsible for determining the suitability of TiMOTION products for a specific application. TiMOTION products are subject to change without prior notice.

System	1 = Single application 2 = Sync, 2 actuators in system 3 = Sync, 3 actuators in system 4 = Sync, 4 actuators in system	5 = Sync, 5 actuators in system 6 = Sync, 6 actuators in system 7 = Sync, 7 actuators in system 8 = Sync, 8 actuators in system
Virtual Upper Limit	Full stroke, Standard default value	
Virtual Lower Limit	0000, standard default value	
Deceleration Before Virtual Upper Limit	0 = No deceleration, standard default value	
Deceleration Before Virtual Lower Limit	0 = No deceleration, standard default value	
Overcurrent Protection	P = Cut current for over current protection, extend and retract over current protection value are standard default value	
Extending Speed	0 = PWM output 100%, standard default value 9 = PWM output 90% 8 = PWM output 80%	7 = PWM output 70% 6 = PWM output 60% 5 = PWM output 50%
Retracting Speed	0 = PWM output 100%, standard default value 9 = PWM output 90% 8 = PWM output 80%	7 = PWM output 70% 6 = PWM output 60% 5 = PWM output 50%
Soft Start - Extending	1 = 1 second, standard default value	2 = 2 seconds 3 = 3 seconds
Soft Start - Retracting	1 = 1 second, standard default value	2 = 2 seconds 3 = 3 seconds