

# TA2PAC

series

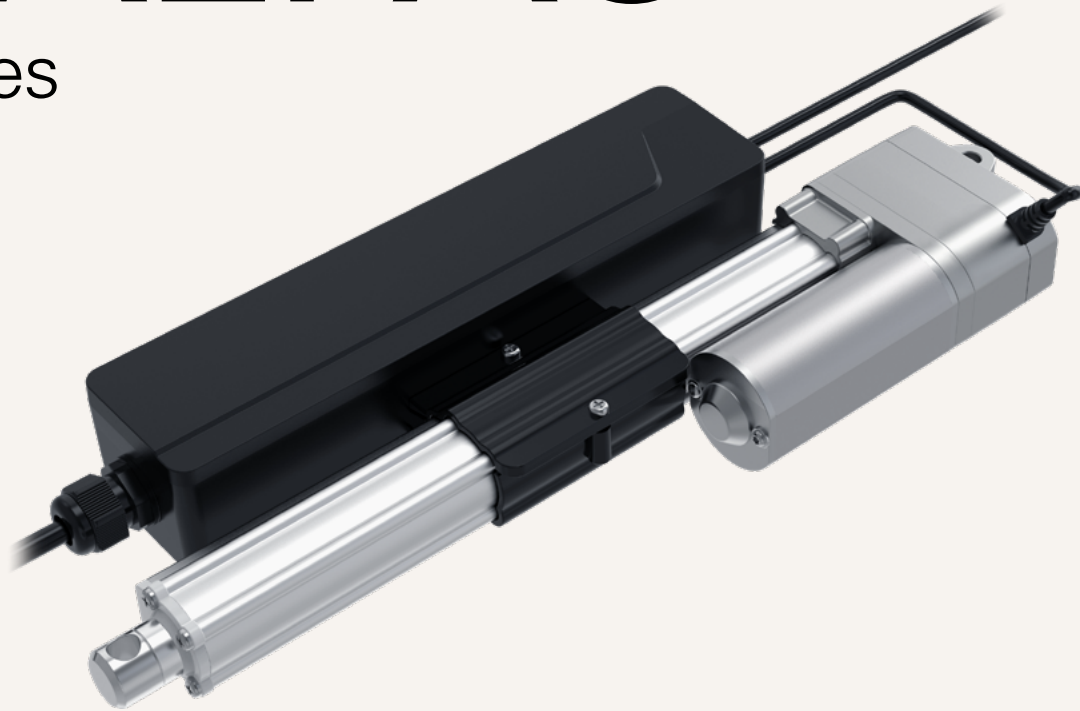

## Product Segments

- **Industrial Motion**

TiMOTION's TA2PAC is a linear actuator with an integrated AC/DC power supply. It is controlled by 1 neutral wire and 2 line wires (extension and retraction), making it ideal for automating ventilation systems in livestock farming.

### General Features

Max. load	2,000N (push/pull)
Max. speed at max. load	7.5mm/s
Max. speed at no load	52mm/s
Retracted length	> 235mm (depending on chosen options)
IP rating	IP66D
Stroke	20~1000mm
Output signals	POT
Voltage	100~240V AC
Operational temperature range	-25°C~+65°C
Operational temperature range at full performance	+5°C~+45°C

## Drawing

Standard Dimensions  
(mm)

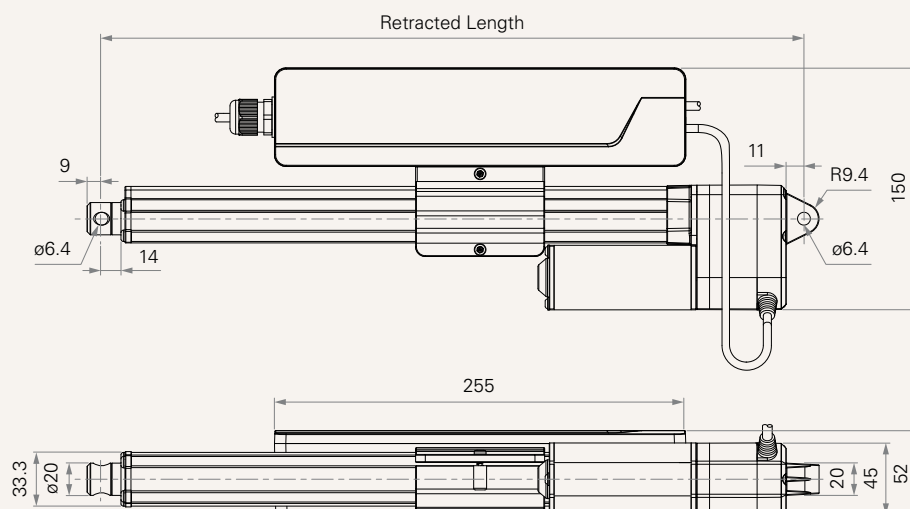

## Load and Speed

CODE	Load (N)		Self Locking Force (N)	Typical Current (A)		Typical Speed (mm/s)		Typical Current (A)		Typical Speed (mm/s)	
	Push	Pull		No Load	With Load	No Load	With Load	No Load	With Load	No Load	With Load
				110V DC				220V DC			
<b>Motor Speed (5200RPM, Duty Cycle 25%)</b>											
<b>A</b>	250	250	250	0.26	0.50	52.0	43.5	0.13	0.25	52.0	43.5
<b>B</b>	500	500	500	0.24	0.54	31.0	27.7	0.12	0.27	31.0	27.7
<b>C</b>	1000	1000	1000	0.24	0.65	16.9	14.2	0.12	0.32	16.9	14.2
<b>D</b>	1500	1500	1500	0.21	0.61	10.8	9.6	0.11	0.30	10.8	9.6
<b>E</b>	2000	2000	2000	0.21	0.50	8.5	7.5	0.11	0.25	8.5	7.5

## Note

- 1 Please refer to the approved drawing for the final authentic value.
- 2 This self-locking force level is reached only when a short circuit is applied on the terminals of the motor. All the TiMOTION control boxes have this feature built-in.
- 3 The current & speed in table are tested when the actuator is extending under push load.
- 4 Standard stroke: Min. 20mm, Max. please refer to below table.

CODE	Load (N)	Max Stroke (mm)
<b>A</b>	≤ 250	1000
<b>B</b>	≤ 500	800
<b>C</b>	≤ 1000	600
<b>D</b>	≤ 1500	500
<b>E</b>	≤ 2000	450

**Performance Data (110V DC Motor)**

Motor Speed (5200RPM)

Speed vs. Load

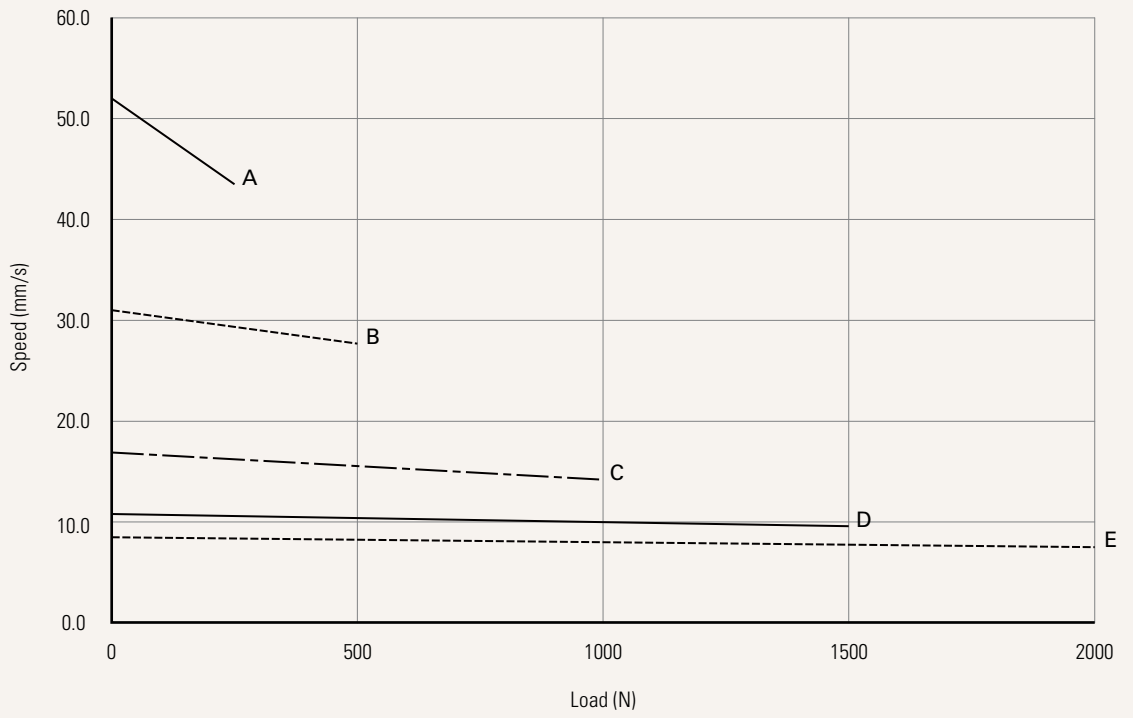

Current vs. Load

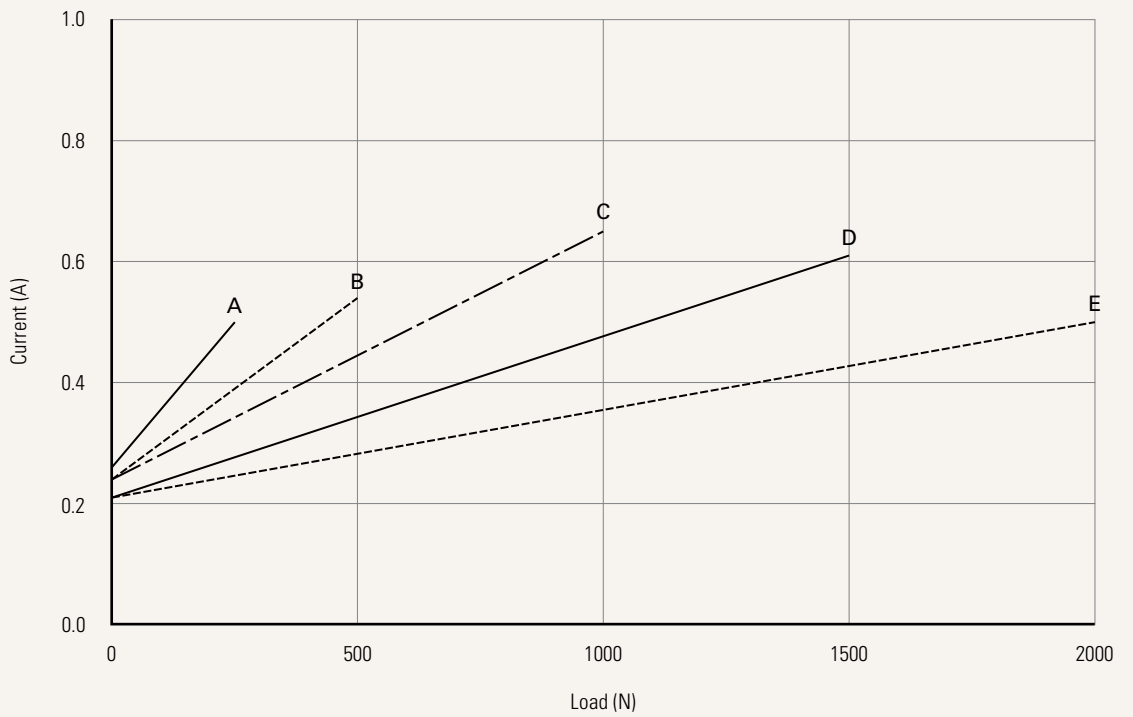

**Performance Data (220V DC Motor)**

Motor Speed (5200RPM)

Speed vs. Load

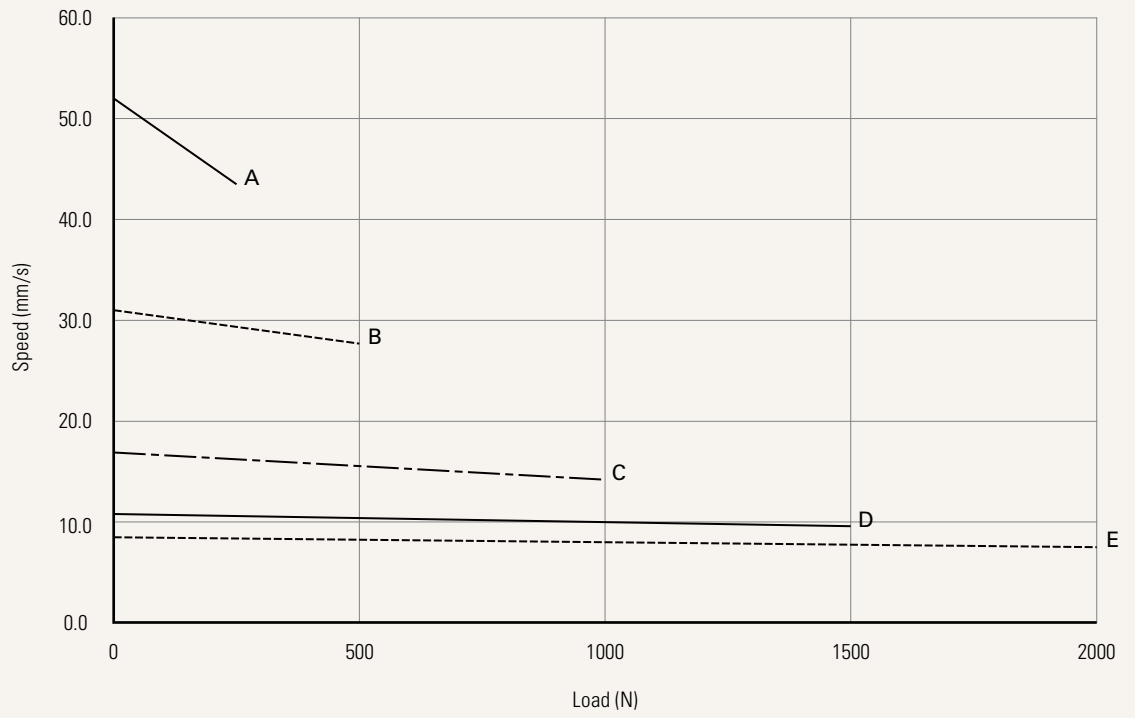

Current vs. Load

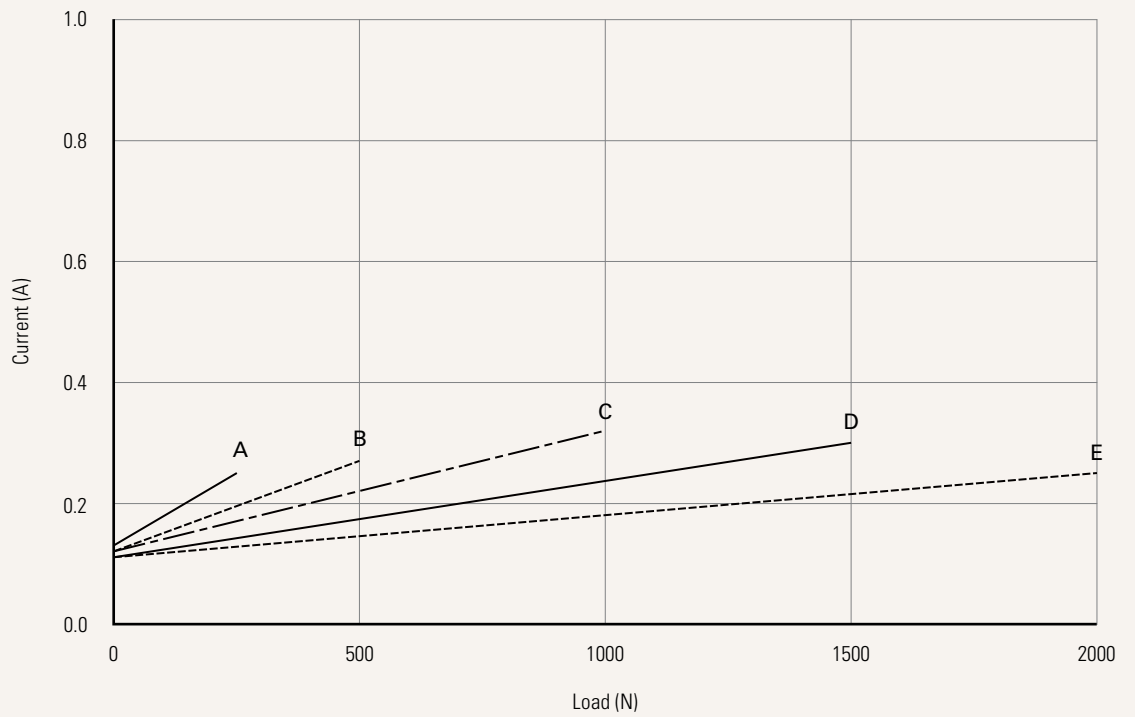

<b>Voltage</b>	U = 100~240VAC	
<b>Load and Speed</b>	<a href="#">See page 2</a>	
<b>Stroke (mm)</b>	<a href="#">See page 2</a>	
<b>Retracted Length (mm)</b>	<a href="#">See page 6</a>	
<b>Rear Attachment (mm)</b> <a href="#">See page 7</a>	1 = Aluminum casting, hole 6.4, one piece casting with gear box 2 = Aluminum casting, hole 8.0, one piece casting with gear box 3 = Aluminum casting, hole 10.0, one piece casting with gear box 4 = Aluminum casting, U clevis, slot 6.0, depth 10.5, hole 6.4, one piece casting with gear box 5 = Aluminum casting, U clevis, slot 6.0, depth 10.5, hole 8.0, one piece casting with gear box 6 = Aluminum casting, U clevis, slot 6.0, depth 10.5, hole 10.0, one piece casting with gear box	
<b>Front Attachment (mm)</b> <a href="#">See page 7</a>	1 = Aluminum casting, hole 6.4 2 = Aluminum casting, hole 8.0 3 = Aluminum CNC, U clevis, slot 6.0, depth 16.0, hole 10.0 4 = Aluminum CNC, U clevis, slot 6.0, depth 16.0, hole 6.4 5 = Aluminum CNC, U clevis, slot 6.0, depth 16.0, hole 8.0	
<b>Direction of Rear Attachment (Counterclockwise)</b> <a href="#">See page 8</a>	1 = 90°	2 = 0°
<b>Functions for Limit Switches</b>	1 = Two switches at full retracted / extended positions to cut current	
<b>Output Signal</b> <a href="#">See page 8</a>	0 = Without	1 = POT
<b>Connector</b> <a href="#">See page 8</a>	1 = Tinned Lead	
<b>AC Power Cable Length (P1) (mm)</b>	1 = 1000, standard	2 = 2000, standard
<b>Signal Cable Length (P2) (mm)</b>	1 = 1000, standard	2 = 2000, standard
<b>Motor Cable Length (mm)</b>	1 = 200, For TA2P	
<b>IP Rating</b>	5 = IP66	6 = IP66D

### Note

1 The TL is designed especially for push applications, not suitable for pull applications.

## Retracted Length (mm)

1. Calculate  $A+B+C = Y$
2. The retracted length of actuator needs to  $\geq \text{Stroke}+Y$

3. For TA2PAC, the retracted length of actuator needs to  $\geq$  the min RL value in table, in case the tube set too short.

A.		
Front Attach.	Rear Attach.	
	1, 2, 3	4, 5, 6
1, 2	+108	+112
3, 4, 5	+120	+124

B.	
Stroke (mm)	Load & Speed Type(N)
	A, B, C, D, E
25~150	-
151~200	+2
201~250	+2
251~300	+2
301~350	+12
351~400	+22
401~450	+32
451~500	+42
501~550	+52
551~600	+62
601~650	+72
651~700	+82
701~750	+92
751~800	+102
801~850	+112
851~900	+122
901~950	+132
951~1000	+142

C.	
Output Signal	
0	-
1	+30

Rear Attach.	Front Attach.	Signal Output	Min RL Value
1, 2, 3	1, 2	0	235
1, 2, 3	1, 2	1	265
1, 2, 3	3, 4, 5	0	248
1, 2, 3	3, 4, 5	1	278
4, 5, 6	1, 2	0	239
4, 5, 6	1, 2	1	269
4, 5, 6	3, 4, 5	0	252
4, 5, 6	3, 4, 5	1	282

## Rear Attachment (mm)

1 = Aluminum casting, hole 6.4, one piece casting with gear box

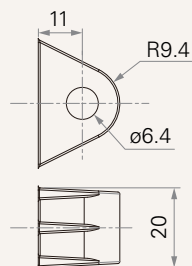

2 = Aluminum casting, hole 8.0, one piece casting with gear box

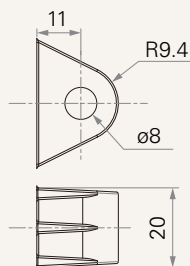

3 = Aluminum casting, hole 10.0, one piece casting with gear box

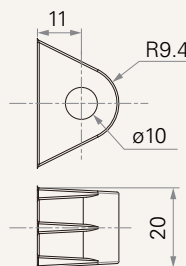

4 = Aluminum casting, U clevis, slot 6.0, depth 10.5, hole 6.4, one piece casting with gear box

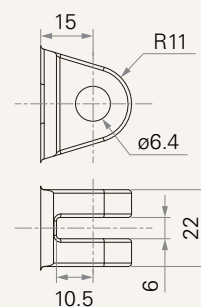

5 = Aluminum casting, U clevis, slot 6.0, depth 10.5, hole 8.0, one piece casting with gear box

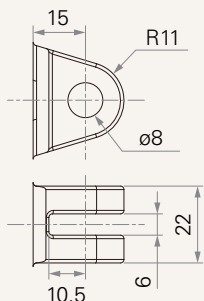

6 = Aluminum casting, U clevis, slot 6.0, depth 10.5, hole 10.0, one piece casting with gear box

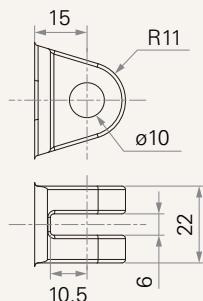

## Front Attachment (mm)

1 = Aluminum casting, hole 6.4

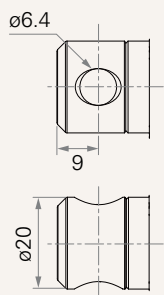

2 = Aluminum casting, hole 8.0

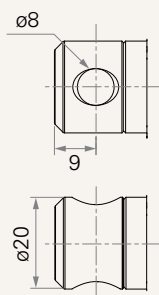

3 = Aluminum CNC, U clevis, slot 6.0, depth 16.0, hole 10.0

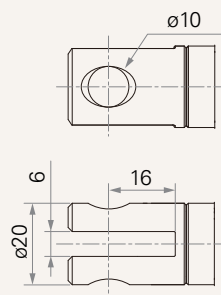

4 = Aluminum CNC, U clevis, slot 6.0, depth 16.0, hole 6.4

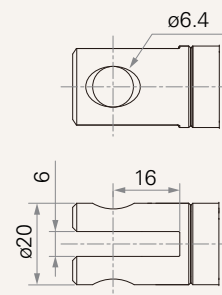

5 = Aluminum CNC, U clevis, slot 6.0, depth 16.0, hole 8.0

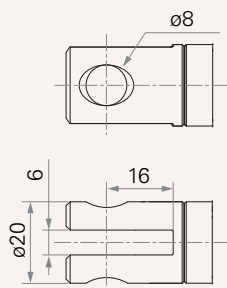

## Direction of Rear Attachment (Counterclockwise)

1 = 90°

2 = 0°

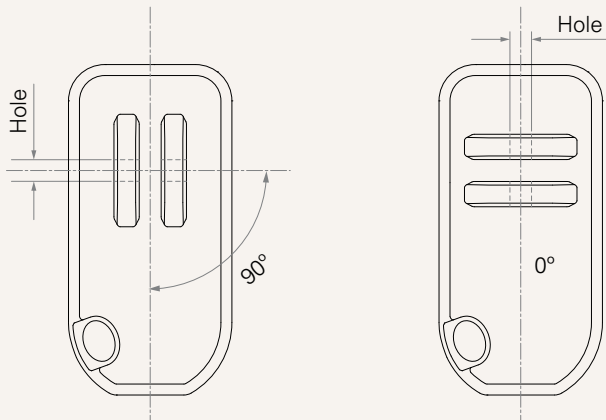

## Wire Definition

### Without T-Smart

Port Number	Wire Color	Wire Gauge (AWG)	Position Feedback	
			0. Without	1. POT
<b>P1 (Power)</b>	● Black	18	Live (EXT+)	Live (EXT+)
	○ White	18	Live (RET+)	Live (RET+)
	● Green	18	Neutral	Neutral
<b>P2 (Signal)</b>	○ White	26	-	Signal VDC in
	● Grey	26	-	POT out
	● Brown	26	-	GND

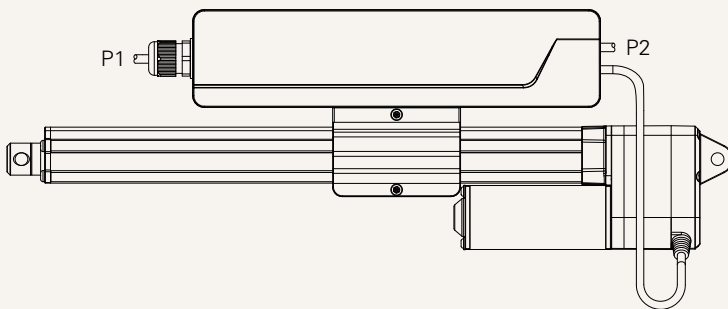

## Connector

1 = Tinned leads

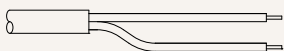

## Terms of Use

The user is responsible for determining the suitability of TiMOTION products for a specific application. TiMOTION products are subject to change without prior notice.